



---

**HY17P68**

**Datasheet**

**6000 Counts DMM Specialized IC  
Embedded Digital RMS**

## Table of Contents

<b>1. FEATURES</b> .....	<b>6</b>
<b>2. 引腳定義</b> .....	<b>7</b>
2.1. LQFP100 引腳圖 .....	7
2.2. LQFP64 引腳圖 .....	8
2.3. 引腳定義與說明 .....	9
2.4. 封裝片標記信息 .....	16
<b>3. 應用電路</b> .....	<b>17</b>
<b>4. FUNCTION OUTLINE</b> .....	<b>18</b>
4.1. Internal Block Diagram.....	18
4.2. 相關說明與支援文件.....	18
4.3. ADC Network .....	19
4.4. Digital Signal Processing(DSP) .....	19
4.5. Analog Input Network.....	20
4.6. Clock System .....	21
4.7. Multi-function Comparator.....	22
4.8. Reset .....	23
4.9. Power Diagram .....	24
4.10. Window Comparator Network And CMP Pin.....	25
4.11. OPAMP.....	25
4.12. Frequency Counter 、CNT Pin .....	26
4.13. GPIO PORT1~4,6~10 .....	26
4.14. Watch Dog.....	29

4.15.	8-bit Timer A1 .....	29
4.16.	16-bit Timer B.....	30
4.17.	LCD .....	31
4.18.	EUART .....	32
4.19.	I2C.....	33
4.20.	SPI.....	33
<b>5.</b>	<b>暫存器列表.....</b>	<b>34</b>
<b>6.</b>	<b>電氣特性 .....</b>	<b>38</b>
6.1.	Recommended operating conditions .....	38
6.2.	Internal RC Oscillator .....	38
6.3.	Supply current into VDD excluding peripherals current.....	40
6.4.	Port 1~4,6~10 .....	42
6.5.	Reset(Brownout) .....	43
6.6.	Multi-function Comparator.....	45
6.7.	Power System .....	46
6.8.	LCD .....	48
6.9.	OPAMP.....	49
6.10.	$\Sigma$ ADC, Power Supply and recommended operating conditions .....	50
6.11.	Analog input and switch performance.....	52
6.12.	Windows Comparator.....	52
6.13.	Build-In EPROM(BIE).....	54
6.14.	Build-In EPROM(BIE) Low voltage control circuit.....	54
<b>7.</b>	<b>修訂貨資訊.....</b>	<b>55</b>

<b>8.</b>	<b>封裝型式資訊.....</b>	<b>56</b>
8.1.	LQFP64(L064) .....	56
8.2.	LQFP100(L100) .....	57
<b>9.</b>	<b>修訂記錄 .....</b>	<b>58</b>

注意：

- 1、本說明書中的內容，隨著產品的改進，有可能不經過預告而更改。請客戶及時到本公司網站下載更新 <http://www.hycontek.com>。
- 2、本規格書中的圖形、應用電路等，因第三方工業所有權引發的問題，本公司不承擔其責任。
- 3、本產品在單獨應用的情況下，本公司保證它的性能、典型應用和功能符合說明書中的條件。當使用在客戶的產品或設備中，以上條件我們不作保證，建議客戶做充分的評估和測試。
- 4、請注意輸入電壓、輸出電壓、負載電流的使用條件，使 IC 內的功耗不超過封裝的容許功耗。對於客戶在超出說明書中規定額定值使用產品，即使是瞬間的使用，由此所造成的損失，本公司不承擔任何責任。
- 5、本產品雖內置防靜電保護電路，但請不要施加超過保護電路性能的過大靜電。
- 6、本規格書中的產品，未經書面許可，不可使用在要求高可靠性的電路中。例如健康醫療器械、防災器械、車輛器械、車載器械及航空器械等對人體產生影響的器械或裝置，不得作為其部件使用。
- 7、本公司一直致力於提高產品的品質和可靠度，但所有的半導體產品都有一定的失效概率，這些失效概率可能會導致一些人身事故、火災事故等。當設計產品時，請充分留意冗餘設計並採用安全指標，這樣可以避免事故的發生。
- 8、本規格書中內容，未經本公司許可，嚴禁用於其他目的之轉載或複製。

### 1. Features

- 8 位元加強型精簡指令集，共有 71 個指令  
包含硬體乘法指令及查表指令 H08D，支援 C Compiler 編譯環境
- 數位電源工作電壓範圍 2.2V to 5.5V，類比電源工作電壓 2.4V to 4.5V，-40~85°C 工作溫度範圍
- 16kWord OTP (One Time Programmable) 程式記憶體，1024Byte 資料記憶體
- 高解析度  $\Sigma\Delta$ ADC
  - 最高取樣頻率達 1MHz
  - 超取樣頻率設置 32~61440
  - 二/三階梳狀濾波器，轉換頻率 30.72ksps
  - 信號放大 x1/2, x1,x2,x4,x8
  - 零輸入電壓，零輸出電壓
  - 高輸入阻抗 (內置輸入緩衝器)
  - 內置絕對溫度感測器
- 內建數位訊號處理(DSP)實現數位 AC 有效值、Peak Hold 等數位計算功能
- 可程式化多功能網路
  - 電壓/電阻/電容換檔量測
  - 定電壓/定電流輸出
  - 元件可自我校正
  - 元件正負極性判別
- 窗型比較器
  - 具有遲滯與 latch 功能，可降低 glitch
  - 可程式化設定比較電壓
  - 可做為短路測試量測、頻率量測或電容充放電頻率量測
- 多功能比較器
  - 可實現 LVD 低電壓檢測功能具多段檢測電壓設置與外部輸入電壓檢測功能
  - 具有遲滯與 latch 功能，可降低 glitch
- 運算放大器
  - 搭配外部元件可將小訊號放大
  - 可程式化成緩衝器
- 類比電壓源 VDDA 具 10mA 穩壓電壓源輸出，快速啟動功能
- 1.2V 的內部類比電路共地電壓源
- 4x36 LCD 液晶驅動器
  - 1/4 Duty、1/3 Bias
  - 內建 Charge Pump 穩壓線路，可提供多種 LCD 偏壓
  - LCD 埠可設定數位輸入輸出埠
- 3 組 24 bits 可程式化計數器可同時量測頻率，週期與占空比
- 8-bit Timer A1
- 16-bit Timer B 模組具 PWM 功能
- UART、SPI、I<sup>2</sup>C(Master/Slave)模組
- Built-In EPROM (BIE)，內建 2.75V 低壓燒錄控制電路
- 內建 Brownout 與 Watch dog timer，可防止 CPU 進入死機模式
- 支援外部石英震盪器 1MHz~16MHz /32768Hz 及內部高精度 RC 震盪器 4.9152MHz/9.8304MHz Mode 多種 CPU 工作時脈切換選擇，可讓使用者達到最佳省電規劃
  - 運行模式
  - 待機模式: LPO 14.5kHz
  - 休眠模式
- Support 8 stack level.
- 封裝
  - LQFP64、LQFP100

## 2. 引腳定義

### 2.1. LQFP100 引腳圖



圖 2-1 HY17P68 LQFP100 引腳圖

註 1：VPP 與 RST 復用同一接口，非燒錄 EPROM 時禁止輸入電壓超過 8.5V

**2.2. LQFP64 引腳圖**

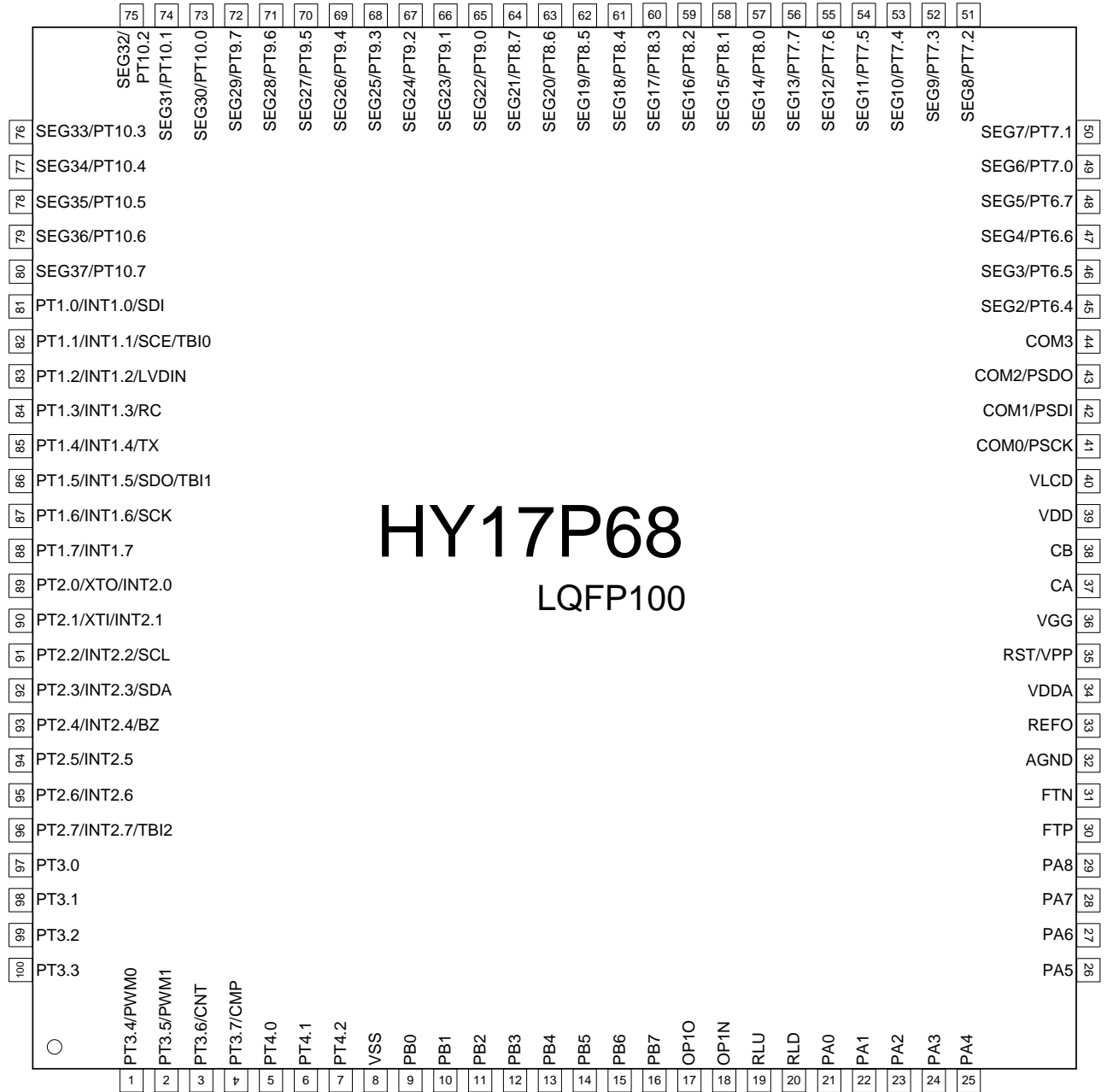

圖 2-2 HY17P68 LQFP64 引腳圖

註 1：VPP 與 RST 復用同一接口，非燒錄 EPROM 時禁止輸入電壓超過 8.5V

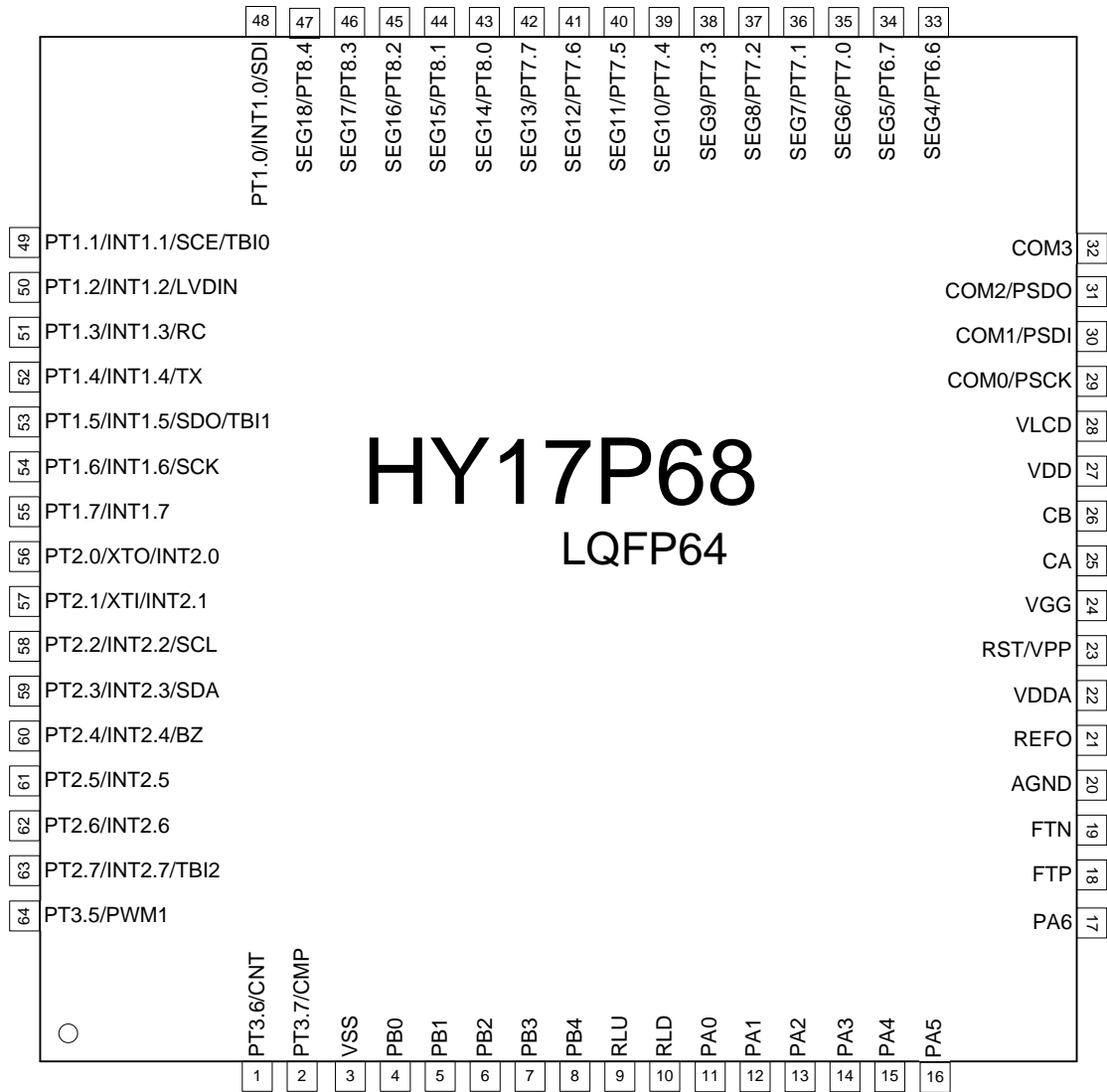

### 2.3. 引腳定義與說明

“I/O”輸入/輸出,“I”輸入,“O”輸出,“S”史密斯觸發,“C”CMOS 特性兼容輸出與輸入,“P”電壓源,“A”類比通道

引腳編號		引腳名稱	引腳特性		功能說明
LQFP100	LQFP64		格式	緩衝	
1	-	PT3.4/PWM0	I/O	S/C	數位輸入/輸出 PWM0 輸出接口
		PT3.4 PWM0	O	C	
2	64	PT3.5/PWM1	I/O	S/C	數位輸入/輸出 PWM1 輸出接口
		PT3.5 PWM1	O	C	
3	1	PT3.6/CNT	I/O	S/C	數位輸入/輸出 頻率計數輸入接口
		PT3.6 CNT	I	S	
4	2	PT3.7/CMP	I/O	S/C	數位輸入/輸出 比較器輸出接口
		PT3.7 CMP	O	S	
5	-	PT4.0	I	S/C	數位輸入/輸出
6	-	PT4.1	I	S/C	數位輸入/輸出
7	-	PT4.2	I	S/C	數位輸入/輸出
8	3	VSS	P	P	晶片工作電壓源接地端
9	4	PB0	I	A	類比輸入通道
10	5	PB1	I	A	類比輸入通道
11	6	PB2	I	A	類比輸入通道
12	7	PB3	I	A	類比輸入通道
13	8	PB4	I	A	類比輸入通道
14	-	PB5	I	A	類比輸入通道
15	-	PB6	I	A	類比輸入通道
16	-	PB7	I	A	類比輸入通道
17	-	OP1O	O	A	OPAMP(OP1) output terminal
18	-	OP1N	I	A	OPAMP(OP1) negative input terminal
19	9	RLU	I/O	A	類比網路開關接口
20	10	RLD	I/O	A	類比網路開關接口
21	11	PA0	I/O	A	類比網路開關接口
22	12	PA1	I/O	A	類比網路開關接口
23	13	PA2	I/O	A	類比網路開關接口
24	14	PA3	I/O	A	類比網路開關接口

引腳編號		引腳名稱	引腳特性		功能說明
LQFP100	LQFP64		格式	緩衝	
25	15	PA4	I/O	A	類比網路開關接口
26	16	PA5	I/O	A	類比網路開關接口
27	17	PA6	I/O	A	類比網路開關接口
28	-	PA7	I/O	A	類比網路開關接口
29	-	PA8	I/O	A	類比網路開關接口
30	18	FTP	I/O	A	前置濾波電容連接口
31	19	FTN	I/O	A	前置濾波電容連接口
32	20	AGND	P	P	類比電源接地端(source: VDDA)
33	21	REFO	P	P	類比電路基準電壓源(source: VDDA)
34	22	VDDA	P	P	穩壓器輸出，類比電路電壓源 (source: VDD)
35	23	RST	I	S	重置晶片
		VPP	P	P	OTP 讀/寫時的電壓源
36	24	VGG	P	P	倍壓穩壓電源輸出，10uF need. (Source: VDD)
37	25	CA	A	A	倍壓電容接口，1~10uF to CB Pin.
38	26	CB	A	A	倍壓電容接口
39	27	VDD	P	P	晶片工作電壓源，1~10uF need.
40	28	VLCD	P	P	LCD 的電壓源，1~10uF need. (Source: VDD)
41	29	COM0	O	A	LCD Segment 輸出
		PSCK	I	S	OTP 讀/寫介面接口
42	30	COM1	O	A	LCD Segment 輸出
		PSDI	I	S	OTP 讀/寫介面接口
43	31	COM2	O	A	LCD Segment 輸出
		PSDO	O	S	OTP 讀/寫介面接口
44	32	COM3	O	A	LCD Segment 輸出
45	-	SEG2	O	A	LCD Segment 輸出
		PT6.4	I/O	S/C	數位輸入/輸出

引腳編號		引腳名稱	引腳特性		功能說明
LQFP100	LQFP64		格式	緩衝	
46	-	SEG3/PT6.5 SEG3 PT6.5	O I/O	A S/C	LCD Segment 輸出 數位輸入/輸出
47	33	SEG4/PT6.6 SEG4 PT6.6	O I/O	A S/C	LCD Segment 輸出 數位輸入/輸出
48	34	SEG5/PT6.7 SEG5 PT6.7	O I/O	A S/C	LCD Segment 輸出 數位輸入/輸出
49	35	SEG6/PT7.0 SEG6 PT7.0	O I/O	A S/C	LCD Segment 輸出 數位輸入/輸出
50	36	SEG7/PT7.1 SEG7 PT7.1	O I/O	A S/C	LCD Segment 輸出 數位輸入/輸出
51	37	SEG8/PT7.2 SEG8 PT7.2	O I/O	A S/C	LCD Segment 輸出 數位輸入/輸出
52	38	SEG9/PT7.3 SEG9 PT7.3	O I/O	A S/C	LCD Segment 輸出 數位輸入/輸出
53	39	SEG10/PT7.4 SEG10 PT7.4	O I/O	A S/C	LCD Segment 輸出 數位輸入/輸出
54	40	SEG11/PT7.5 SEG11 PT7.5	O I/O	A S/C	LCD Segment 輸出 數位輸入/輸出
55	41	SEG12/PT7.6 SEG12 PT7.6	O I/O	A S/C	LCD Segment 輸出 數位輸入/輸出
56	42	SEG13/PT7.7 SEG13 PT7.7	O I/O	A S/C	LCD Segment 輸出 數位輸入/輸出
57	43	SEG14/PT8.0 SEG14 PT8.0	O I/O	A S/C	LCD Segment 輸出 數位輸入/輸出

引腳編號		引腳名稱	引腳特性		功能說明
LQFP100	LQFP64		格式	緩衝	
58	44	SEG15/PT8.1 SEG15 PT8.1	O I/O	A S/C	LCD Segment 輸出 數位輸入/輸出
59	45	SEG16/PT8.2 SEG16 PT8.2	O I/O	A S/C	LCD Segment 輸出 數位輸入/輸出
60	46	SEG17/PT8.3 SEG17 PT8.3	O I/O	A S/C	LCD Segment 輸出 數位輸入/輸出
61	47	SEG18/PT8.4 SEG18 PT8.4	O I/O	A S/C	LCD Segment 輸出 數位輸入/輸出
62	-	SEG19/PT8.5 SEG19 PT8.5	O I/O	A S/C	LCD Segment 輸出 數位輸入/輸出
63	-	SEG20/PT8.6 SEG20 PT8.6	O I/O	A S/C	LCD Segment 輸出 數位輸入/輸出
64	-	SEG21/PT8.7 SEG21 PT8.7	O I/O	A S/C	LCD Segment 輸出 數位輸入/輸出
65	-	SEG22/PT9.0 SEG22 PT9.0	O I/O	A S/C	LCD Segment 輸出 數位輸入/輸出
66	-	SEG23/PT9.1 SEG23 PT9.1	O I/O	A S/C	LCD Segment 輸出 數位輸入/輸出
67	-	SEG24/PT9.2 SEG24 PT9.2	O I/O	A S/C	LCD Segment 輸出 數位輸入/輸出
68	-	SEG25/PT9.3 SEG25 PT9.3	O I/O	A S/C	LCD Segment 輸出 數位輸入/輸出
69	-	SEG26/PT9.4 SEG26 PT9.4	O I/O	A S/C	LCD Segment 輸出 數位輸入/輸出

引腳編號		引腳名稱	引腳特性		功能說明
LQFP100	LQFP64		格式	緩衝	
70	-	SEG27/PT9.5 SEG27 PT9.5	O I/O	A S/C	LCD Segment 輸出 數位輸入/輸出
71	-	SEG28/PT9.6 SEG28 PT9.6	O I/O	A S/C	LCD Segment 輸出 數位輸入/輸出
72	-	SEG29/PT9.7 SEG29 PT9.7	O I/O	A S/C	LCD Segment 輸出 數位輸入/輸出
73	-	SEG30/PT10.0 SEG30 PT10.0	O I/O	A S/C	LCD Segment 輸出 數位輸入/輸出
74	-	SEG31/PT10.1 SEG31 PT10.1	O I/O	A S/C	LCD Segment 輸出 數位輸入/輸出
75	-	SEG32/PT10.2 SEG32 PT10.2	O I/O	A S/C	LCD Segment 輸出 數位輸入/輸出
76	-	SEG33/PT10.3 SEG33 PT10.3	O I/O	A S/C	LCD Segment 輸出 數位輸入/輸出
77	-	SEG34/PT10.4 SEG34 PT10.4	O I/O	A S/C	LCD Segment 輸出 數位輸入/輸出
78	-	SEG35/PT10.5 SEG35 PT10.5	O I/O	A S/C	LCD Segment 輸出 數位輸入/輸出
79	-	SEG36/PT10.6 SEG36 PT10.6	O I/O	A S/C	LCD Segment 輸出 數位輸入/輸出
80	-	SEG37/PT10.7 SEG37 PT10.7	O I/O	A S/C	LCD Segment 輸出 數位輸入/輸出

引腳編號		引腳名稱	引腳特性		功能說明
LQFP100	LQFP64		格式	緩衝	
81	48	PT1.0/INT1.0/SDI			
		PT1.0	I/O	S/C	數位輸入/輸出
		INT1.0	I	S	中斷源 E0IF
		SDI	I/O	S	SPI 通訊介面接口
82	49	PT1.1/INT1.1/SCE/TBI0			
		PT1.1	I/O	S/C	數位輸入/輸出
		INT1.1	I	S	中斷源 E1IF
		SCE	I	S	SPI 通訊介面接口
		TBI0	I	S	TimerB 啟動輸入接口
83	50	PT1.2/INT1.2/LVDIN			
		PT1.2	I/O	S/C	數位輸入/輸出
		INT1.2	I	S	中斷源 E2IF
		LVDIN	A	A	LVD 外部信號輸入接口
84	51	PT1.3/INT1.3/RC			
		PT1.3	I/O	S/C	數位輸入/輸出
		INT1.3	I	S	中斷源 E3IF
		RC	I	S	EUART 通訊介面接口
85	52	PT1.4/INT1.4/TX			
		PT1.4	I/O	S/C	數位輸入/輸出
		INT1.4	I	S	中斷源 INTF1.4
		TX	O	C	EUART 通訊介面接口
86	53	PT1.5/INT1.5/SDO/TBI1			
		PT1.5	I/O	S/C	數位輸入/輸出
		INT1.5	I	S	中斷源 INTF1.5
		SDO	I/O	S	SPI 通訊介面接口
		TBI1	I	S	TimerB 啟動輸入接口
87	54	PT1.6/INT1.6/SCK			
		PT1.6	I/O	S/C	數位輸入/輸出
		INT1.6	I	S	中斷源 INTF1.6
		SCK	I/O	S	SPI 通訊介面接口
88	55	PT1.7/INT1.7			
		PT1.7	I/O	S/C	數位輸入/輸出
		INT1.7	I	S	中斷源 INTF1.7

引腳編號		引腳名稱	引腳特性		功能說明
LQFP100	LQFP64		格式	緩衝	
89	56	PT2.0/XTO/INT2.0	I/O	S/C	數位輸入/輸出 外接振盪器輸出端 中斷源 INTF2.0
		PT2.0	A	A	
		INT2.0	I	S	
90	57	PT2.1/XTI/INT2.1	I/O	S/C	數位輸入/輸出 外接振盪器輸入端 中斷源 INTF2.1
		PT2.1	A	A	
		INT2.1	I	S	
91	58	PT2.2/INT2.2/SCL	I/O	S/C	數位輸入/輸出 中斷源 INTF2.2 I2C 通訊介面引腳
		PT2.2	I	S	
		SCL	I/O	S	
92	59	PT2.3/INT2.3/SDA	I/O	S/C	數位輸入/輸出 中斷源 INTF2.3 I2C 通訊介面引腳
		PT2.3	I	S	
		SDA	I/O	S	
93	60	PT2.4/INT2.4/BZ	I/O	S/C	數位輸入/輸出 中斷源 INTF2.4 蜂鳴器輸出端
		PT2.4	I	S	
		BZ	O	C	
94	61	PT2.5/INT2.5	I/O	S/C	數位輸入/輸出 中斷源 INTF2.5
		INT2.5	I	S	
95	62	PT2.6/INT2.6	I/O	S/C	數位輸入/輸出 中斷源 INTF2.6
		INT2.6	I	S	
96	63	PT2.7/INT2.7/TBI2	I/O	S/C	數位輸入/輸出 中斷源 INTF2.7 TimerB 啟動輸入接口
		PT2.7	I	S	
		TBI2	I	S	
97	-	PT3.0	I/O	S/C	數位輸入/輸出
98	-	PT3.1	I/O	S/C	數位輸入/輸出
99	-	PT3.2	I/O	S/C	數位輸入/輸出
100	-	PT3.3	I/O	S/C	數位輸入/輸出

表 2-1 引腳編號與說明

## 2.4. 封裝片標記信息

### 2.4.1. LQFP 封裝片標記信息

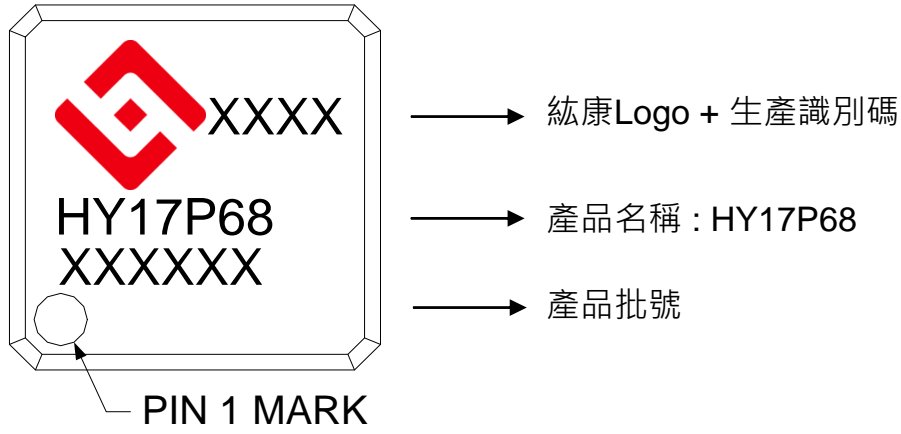



3. 應用電路



圖 3-1 DMM 應用電路

## 4. Function Outline

### 4.1. Internal Block Diagram

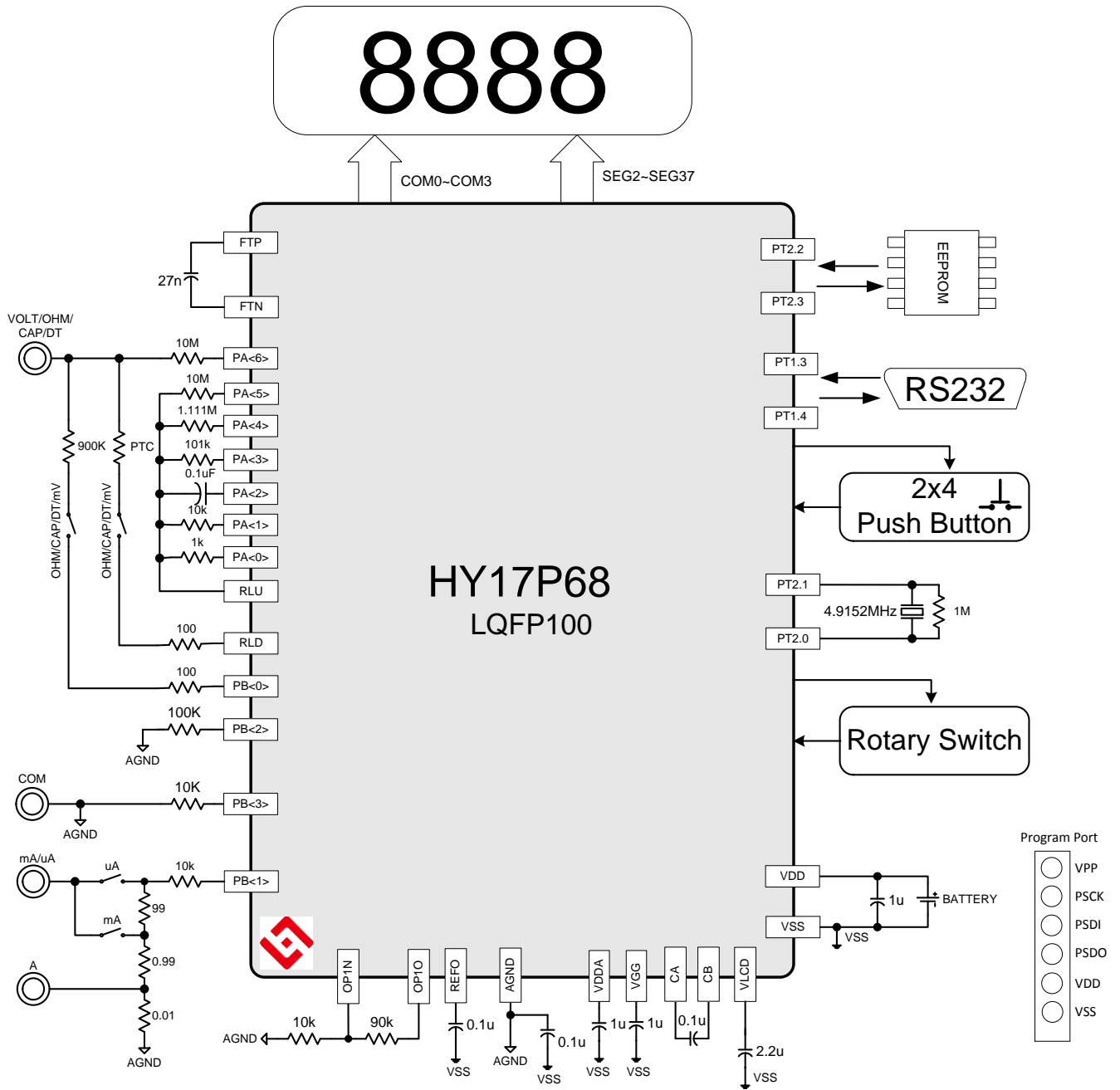

圖 4-1 HY17P68 內部方塊圖

### 4.2. 相關說明與支援文件

晶片功能相關使用說明書

DS-HY17P68

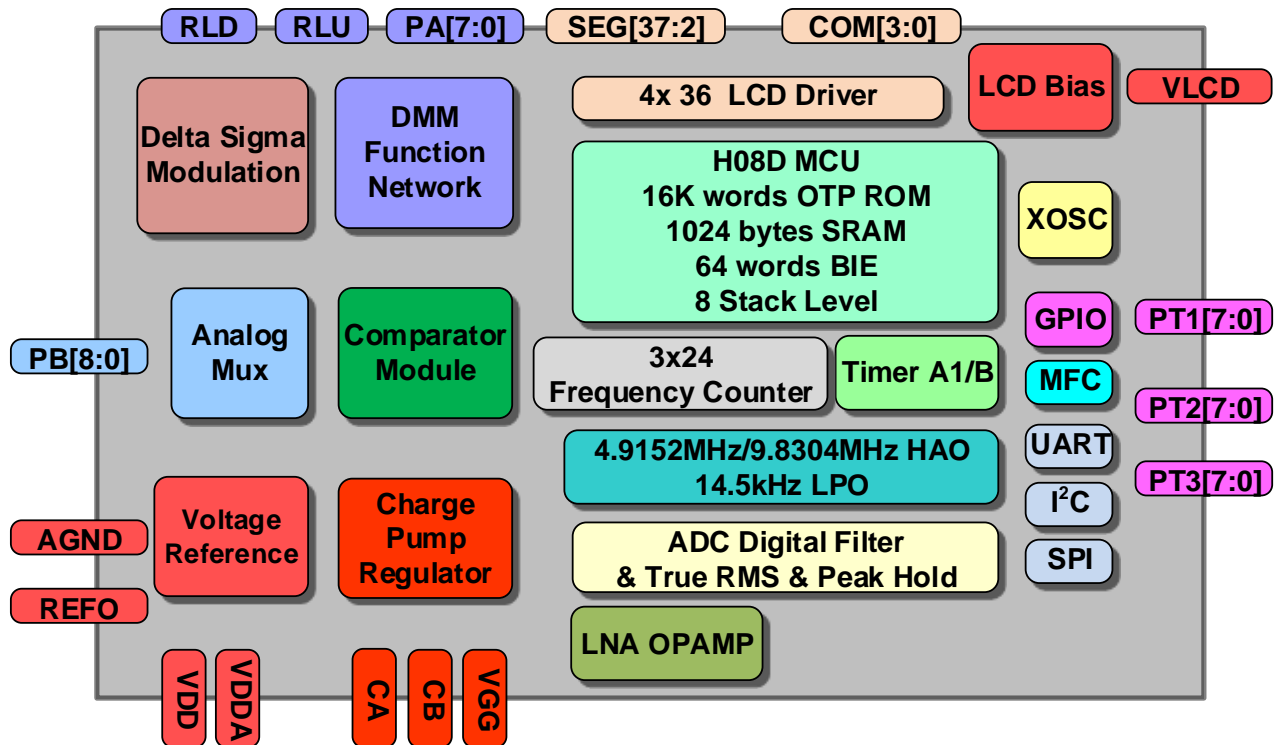
HY17P68 說明書

UG-HY17S68

HY17S68 使用說明書

APD-CORE005

H08D 指令集說明書

開發工具相關使用說明書

APD-HY17PIDE001

HY17P 系列開發工具軟體使用說明書

APD-HY17PIDE005

HY17P6x 系列開發工具硬體使用說明書

APD-HYIDE013

整合型燒錄器使用說明書

APD-HYIDE014

HY10000-WK08C 整合型燒錄器線上更新說明書

APD-OTP005

OTP 燒錄引腳資訊

產品生產相關使用說明書

APD-HY17PIDE004

HY17P 系列 HexLoader 說明書

**4.3. ADC Network**



圖 4-2 ΣΔADC Network 方塊圖

**4.4. Digital Signal Processing(DSP)**

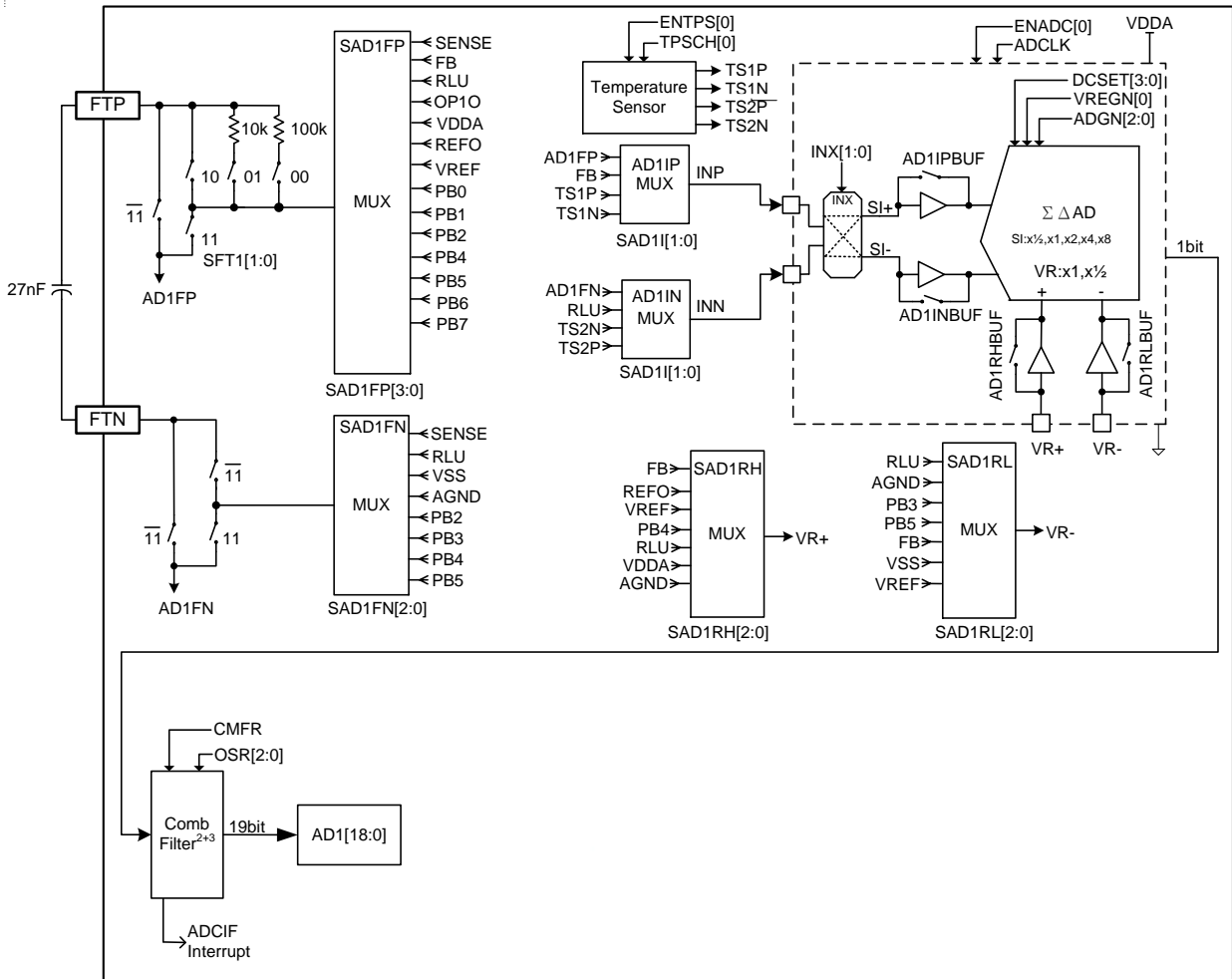

圖 4-3 Digital Signal Processing(DSP) 方塊圖

### 4.5. Analog Input Network

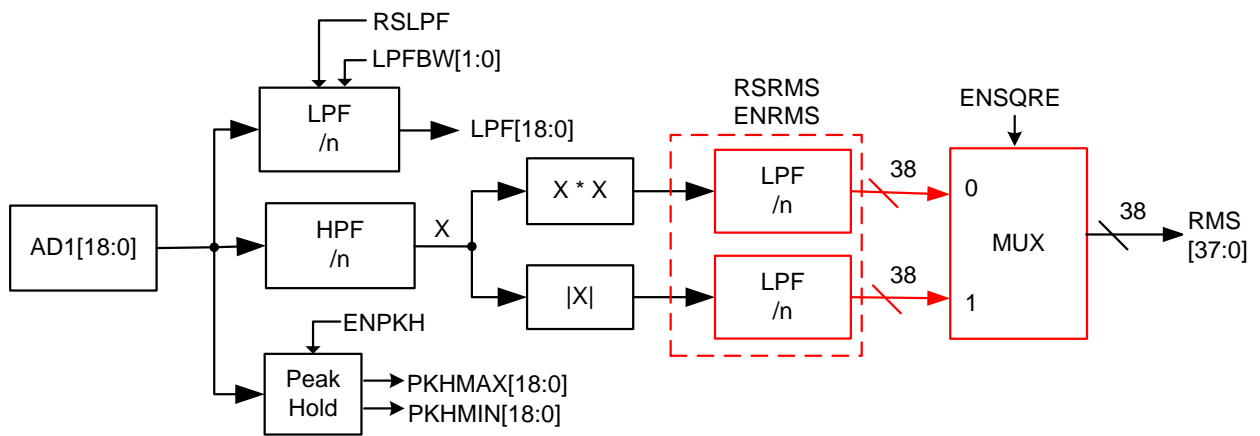

圖 4-4 Analog Input Network 方塊圖

### 4.6. Clock System



圖 4-5 Clock System 方塊圖(一)

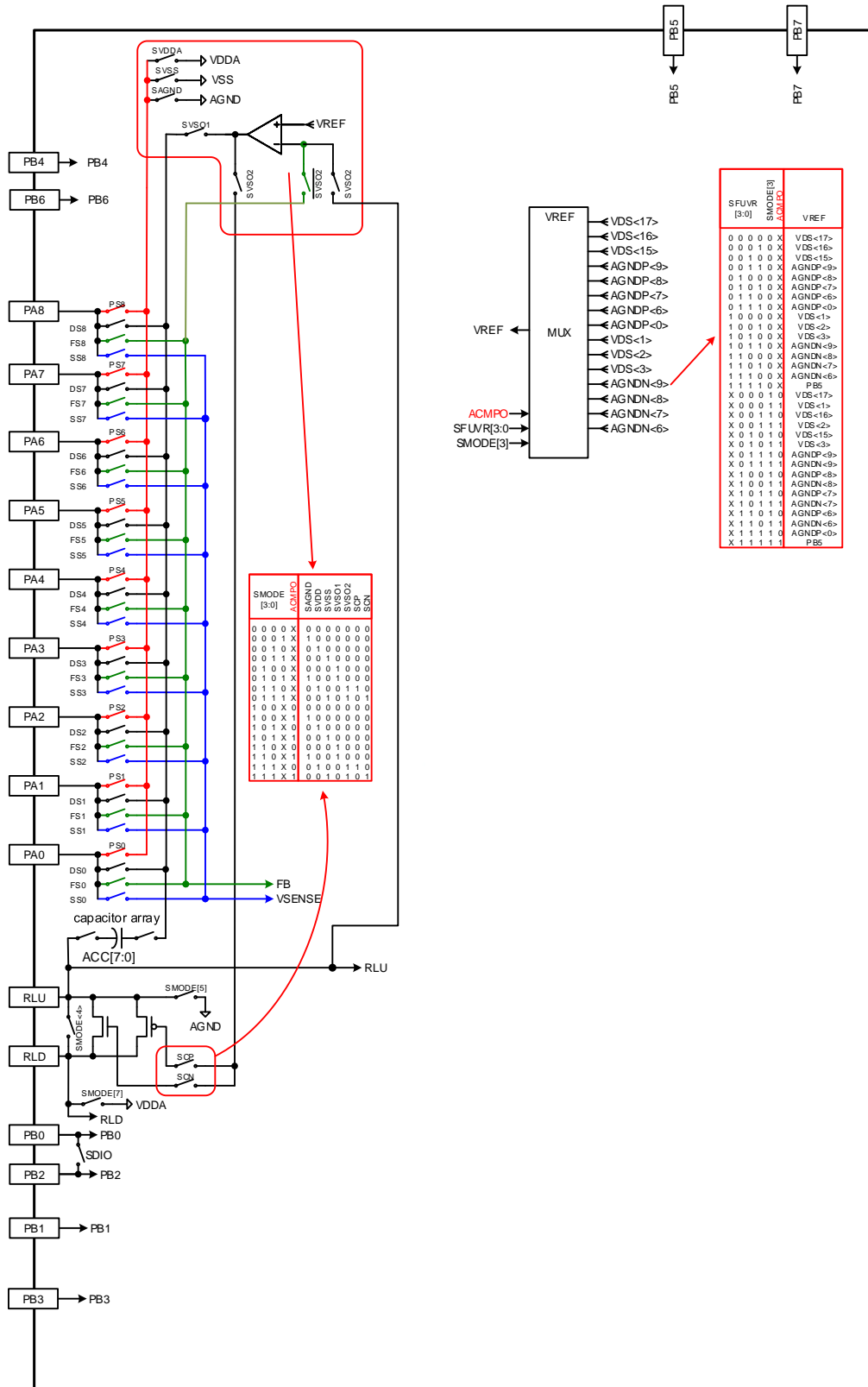

圖 4-6 Clock System 方塊圖(二)

**4.7. Multi-function Comparator**

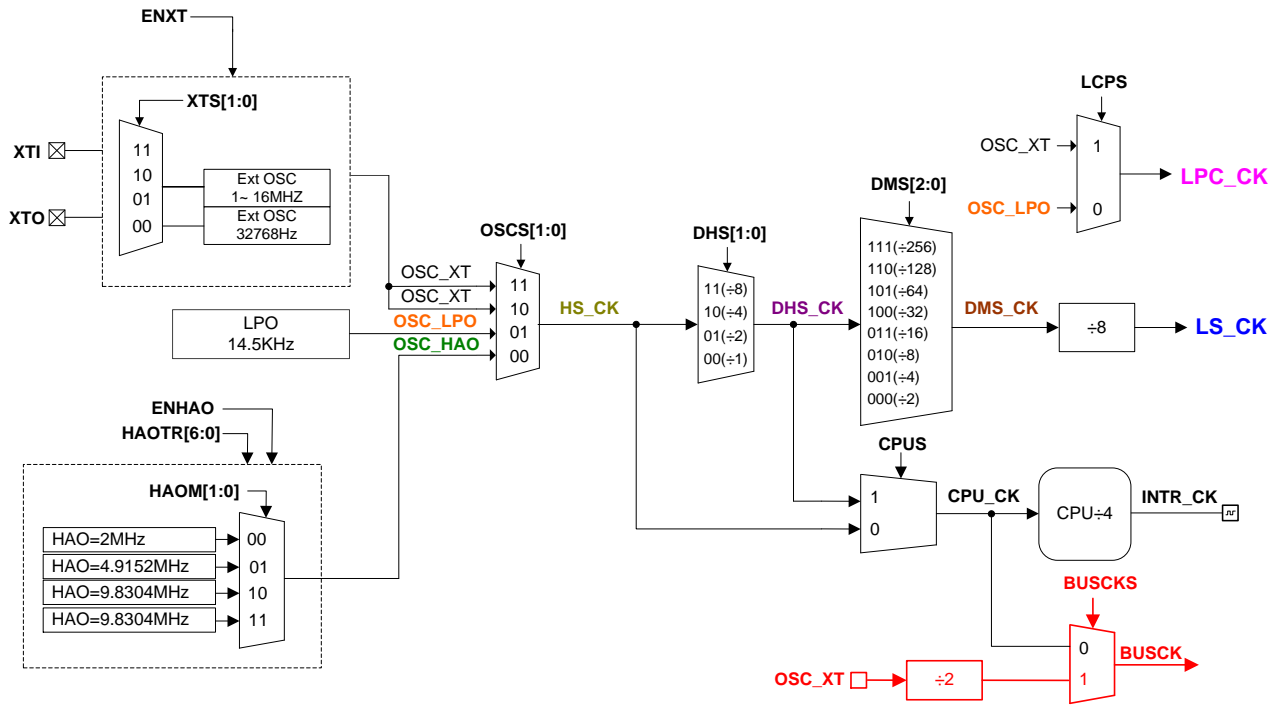

圖 4-7 Multi-function Comparator 方塊圖

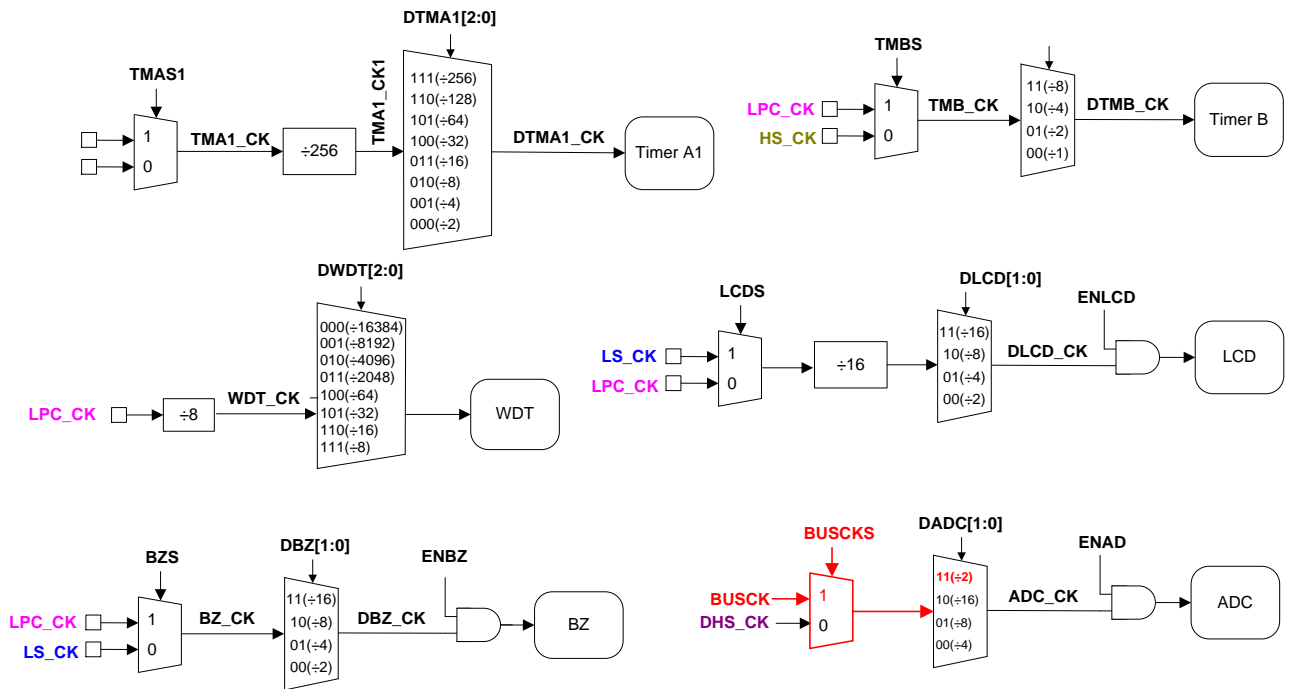
**4.8. Reset**

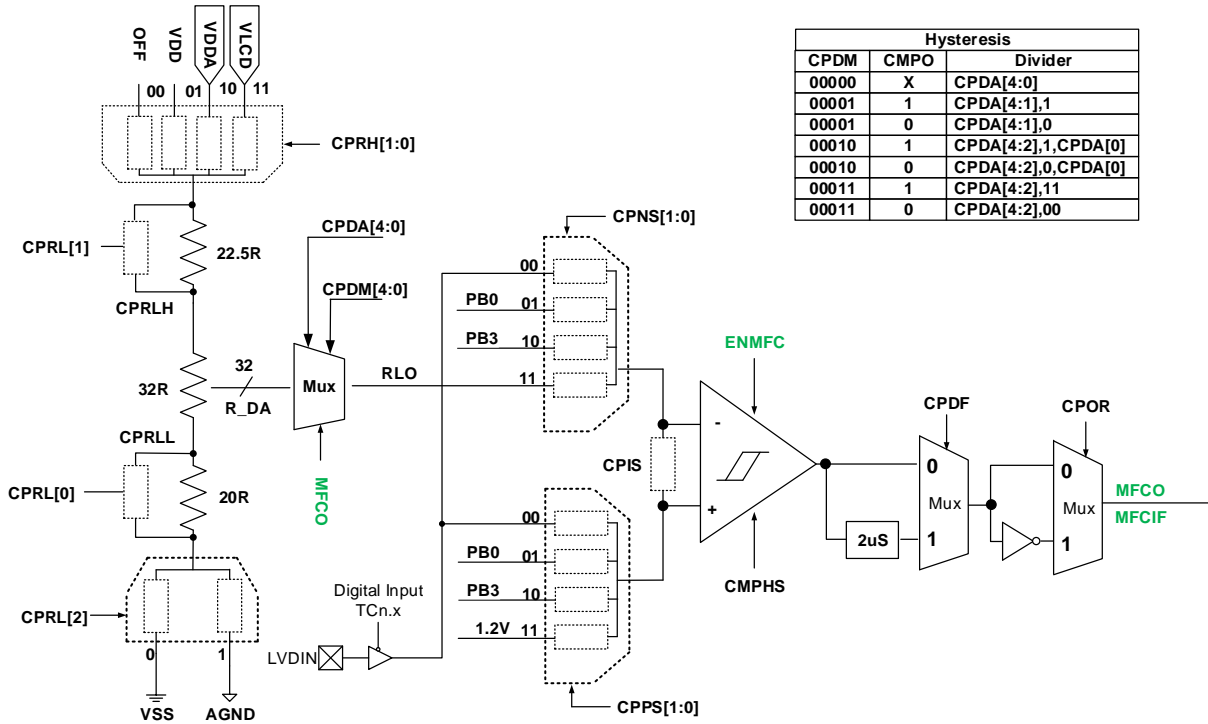

圖 4-8 Reset 方塊圖

### 4.9. Power Diagram



圖 4-9 Power System 方塊圖

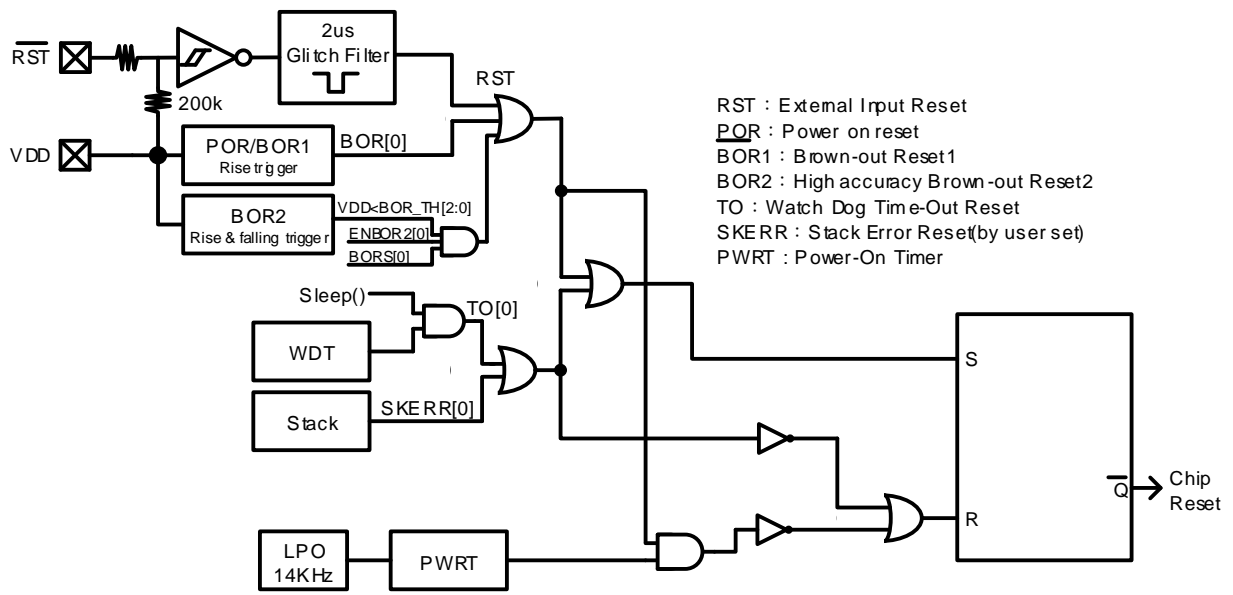

**4.10. Window Comparator Network And CMP Pin**

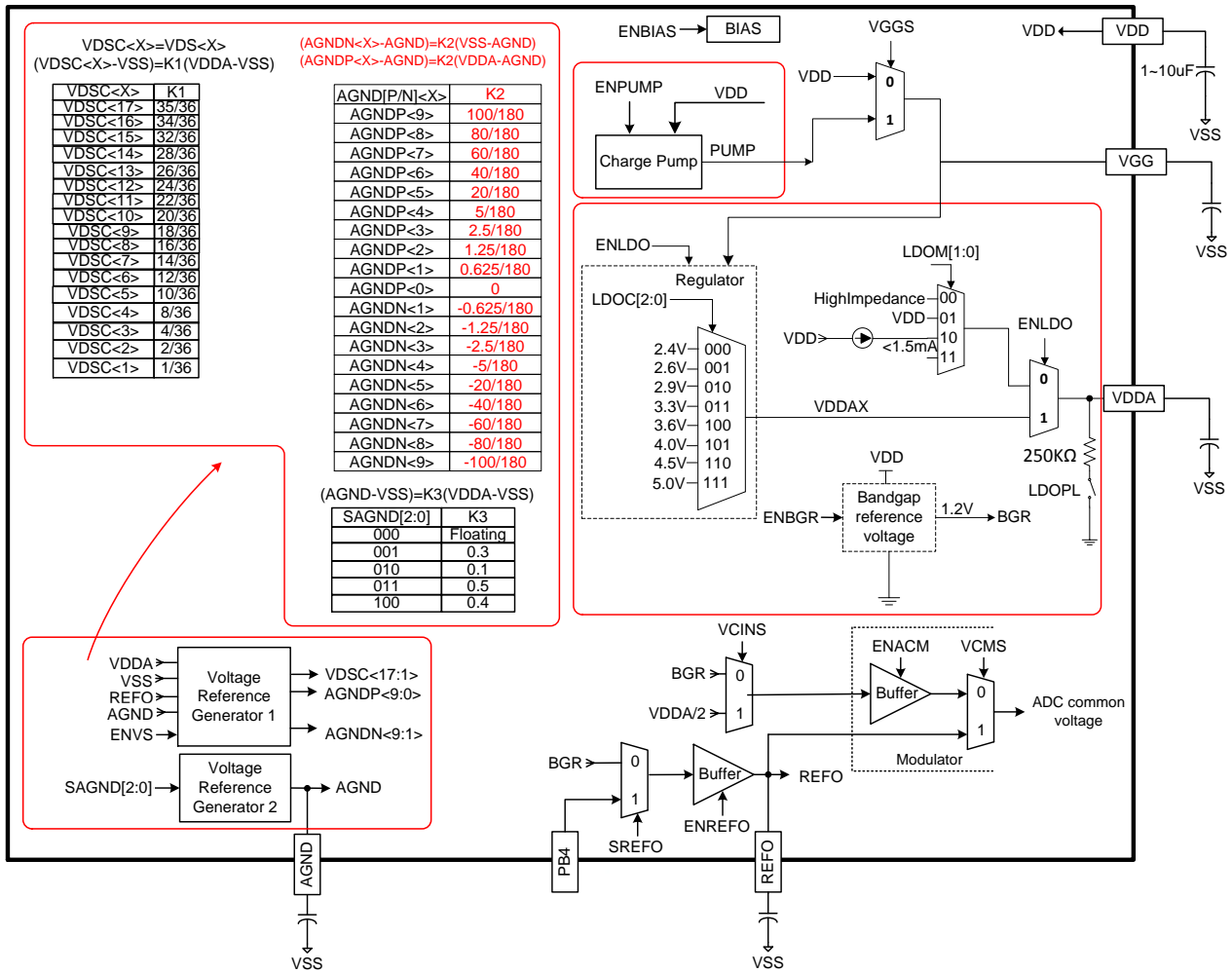

圖 4-10 Window Comparator Network 方塊圖

**4.11. OPAMP**

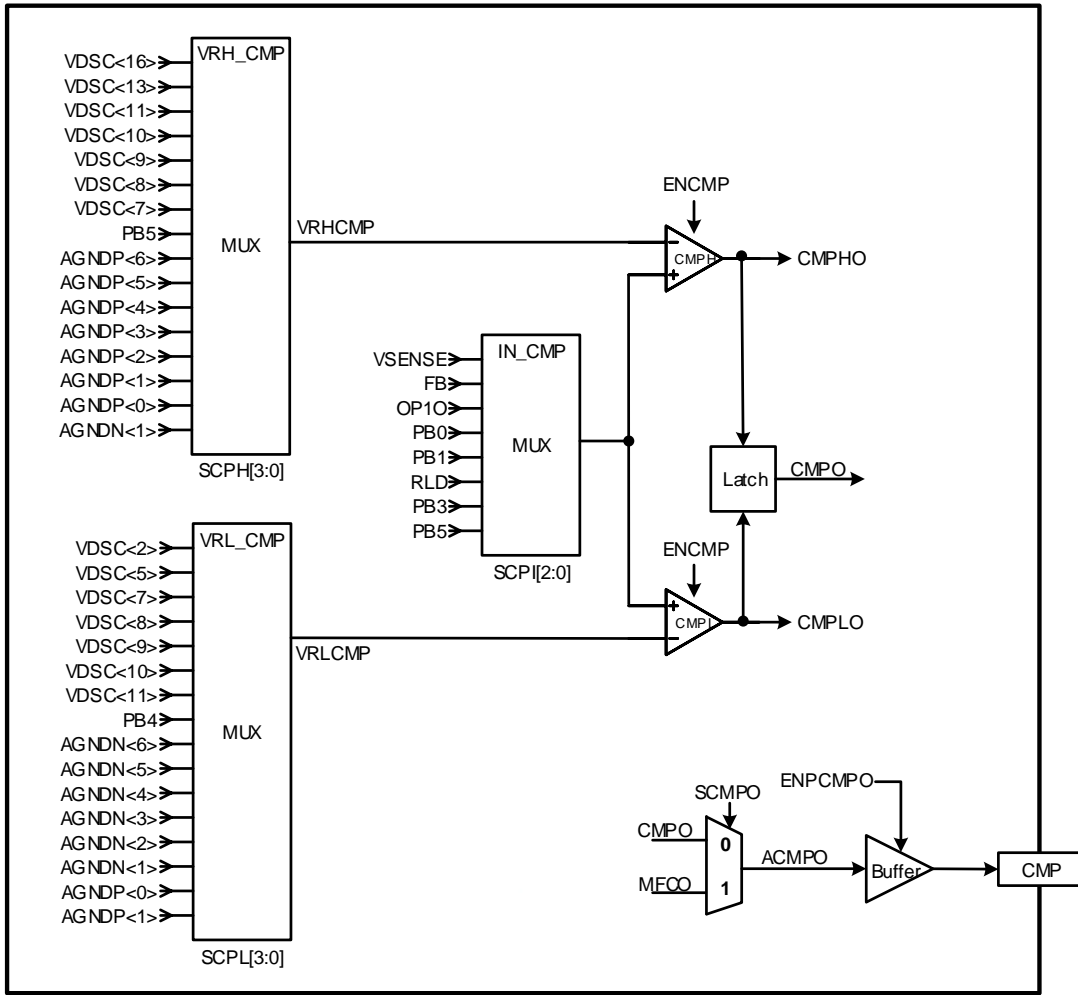

圖 4-11 OPAMP 方塊圖

**4.12. Frequency Counter · CNT Pin**

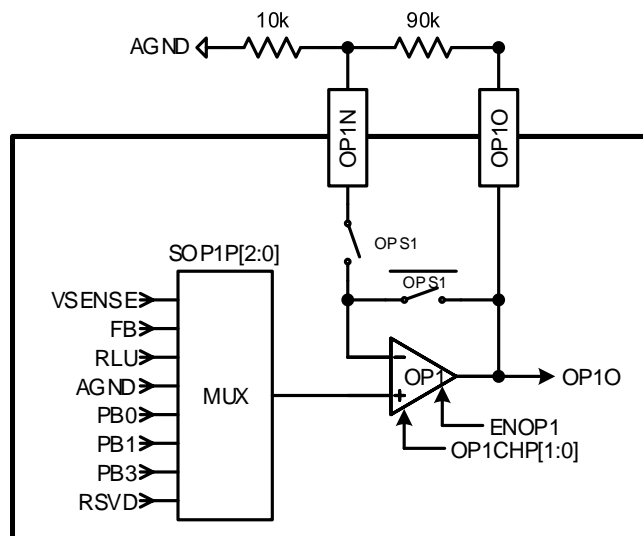

圖 4-12 Frequency Counter 方塊圖

**4.13. GPIO PORT1~4,6~10**



圖 4-13a GPIO PORT1~4 方塊圖

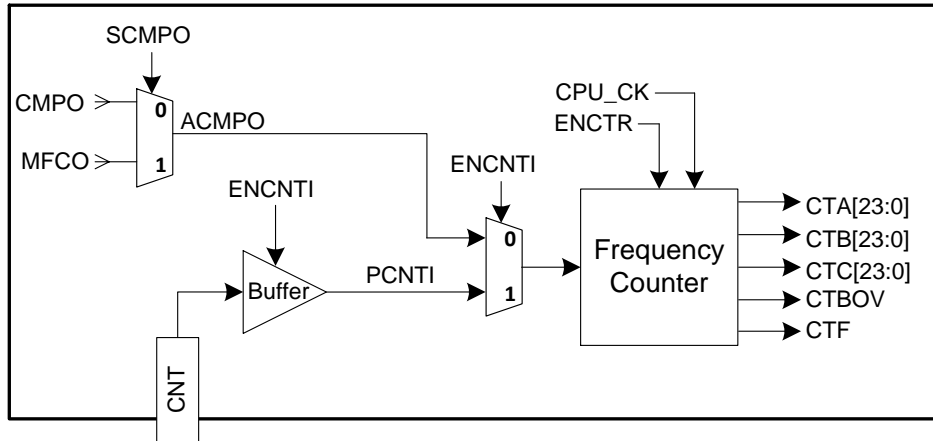

圖 4-14b I/O PORT6~7 架構方塊圖

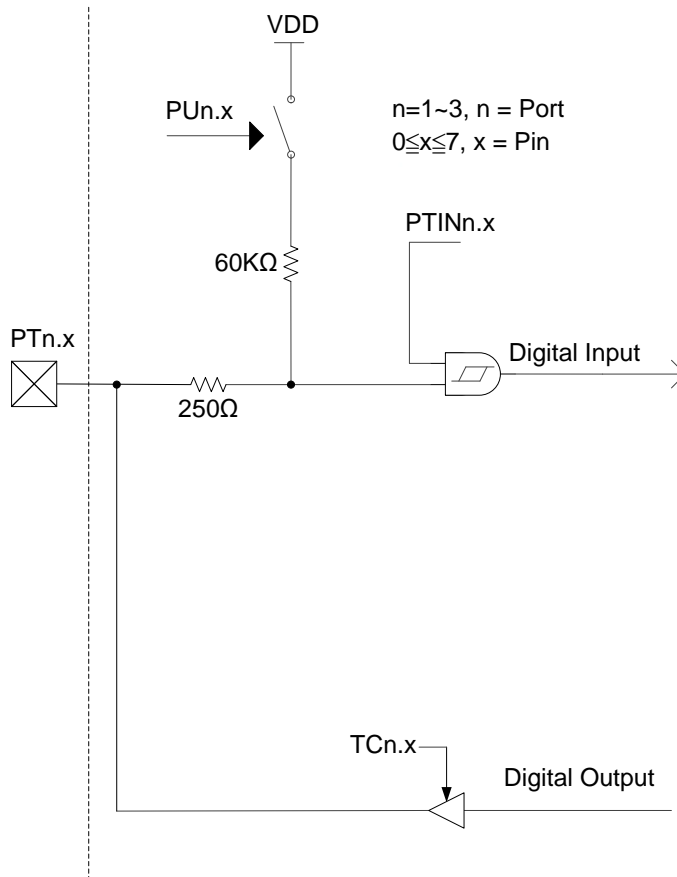

圖 4-15c I/O PORT8,10 架構方塊圖

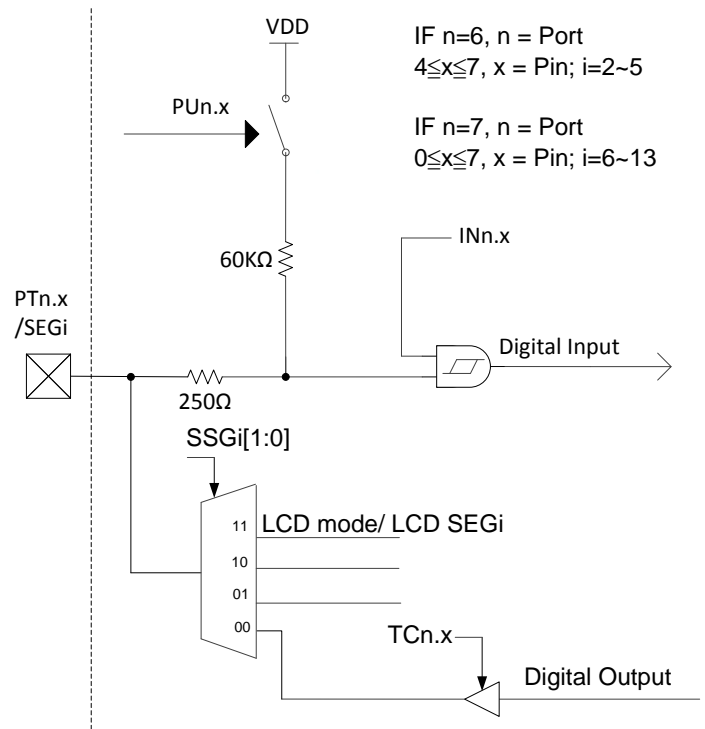
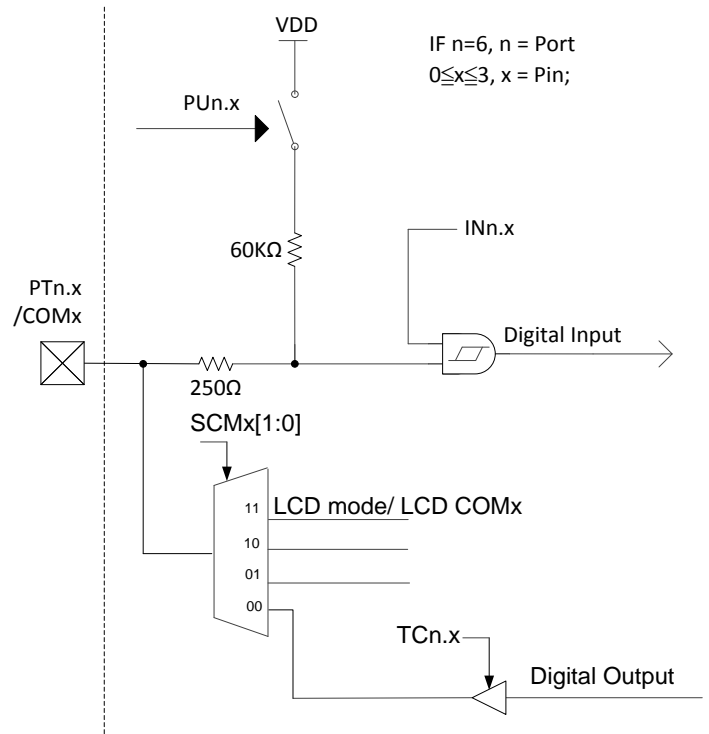

圖 4-16d I/O PORT9~10 架構方塊圖

### 4.14. Watch Dog

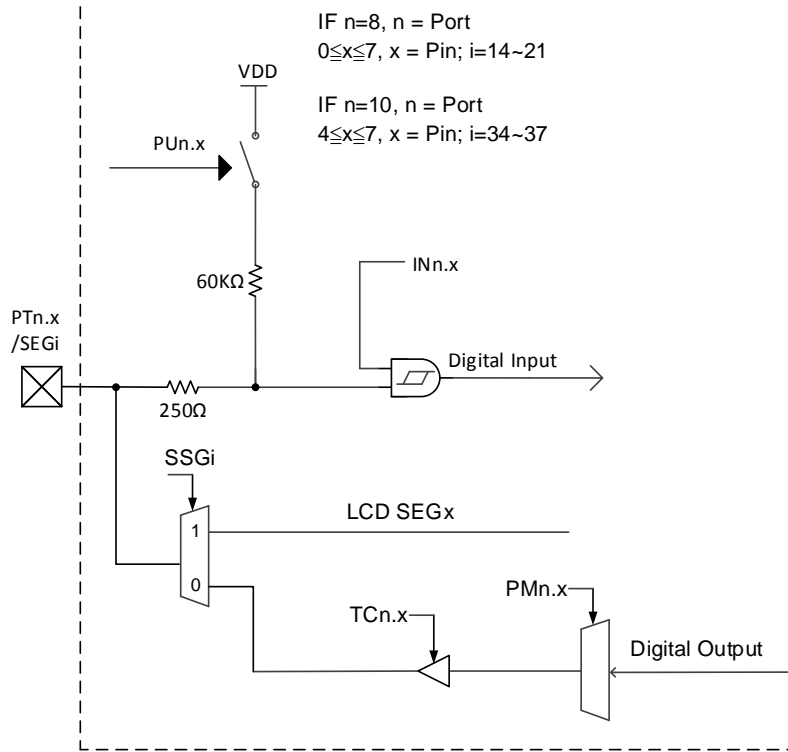

圖 4-17 Watch Dog 方塊圖

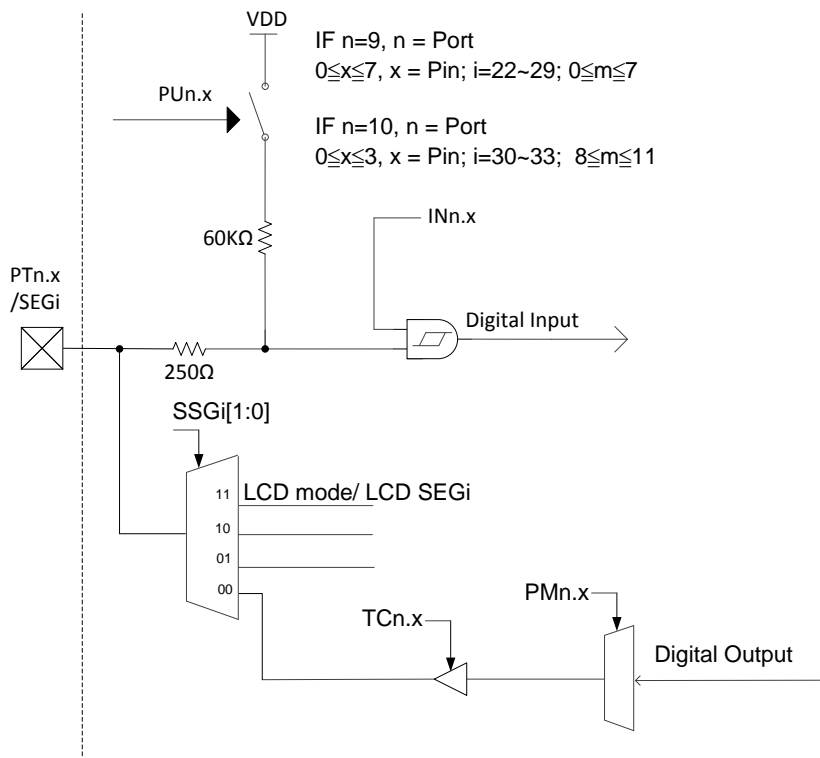
### 4.15.8-bit Timer A1

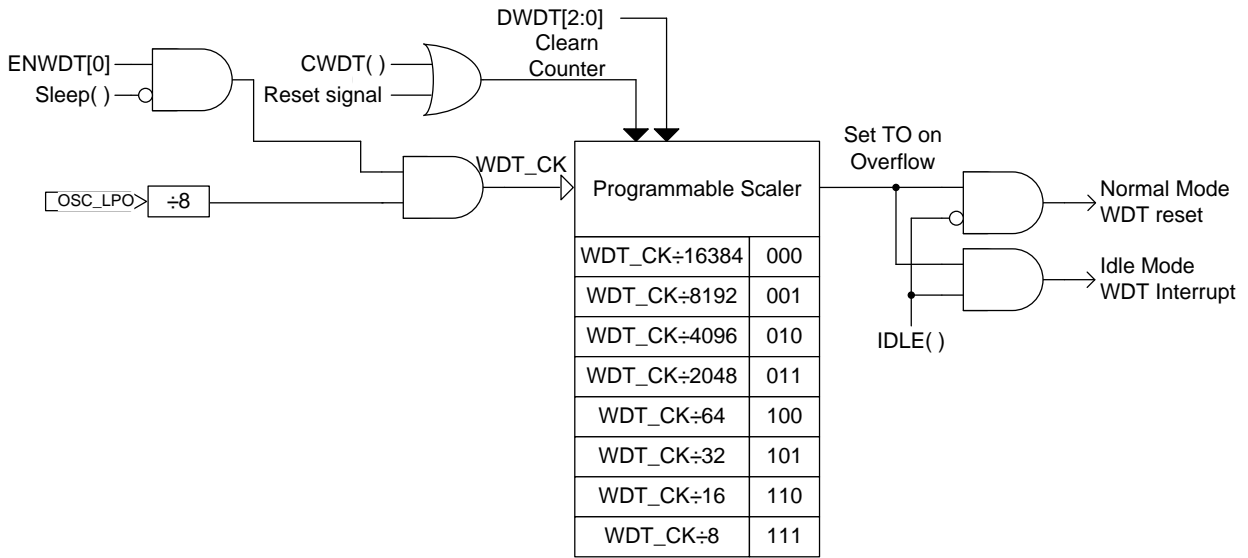

圖 4-18 8-bit Timer A1 方塊圖

**4.16. 16-bit Timer B**

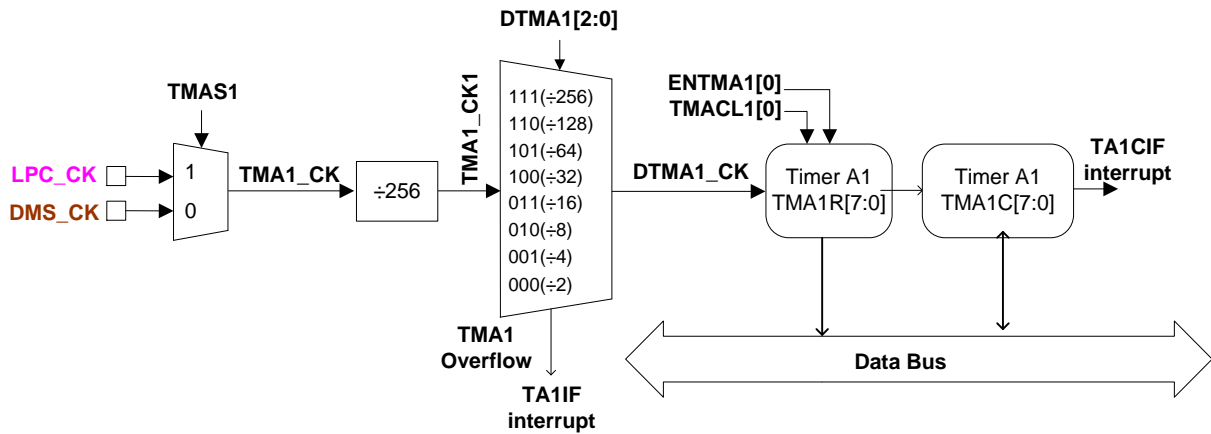

圖 4-19 16-bit Timer B 方塊圖

4.17. LCD

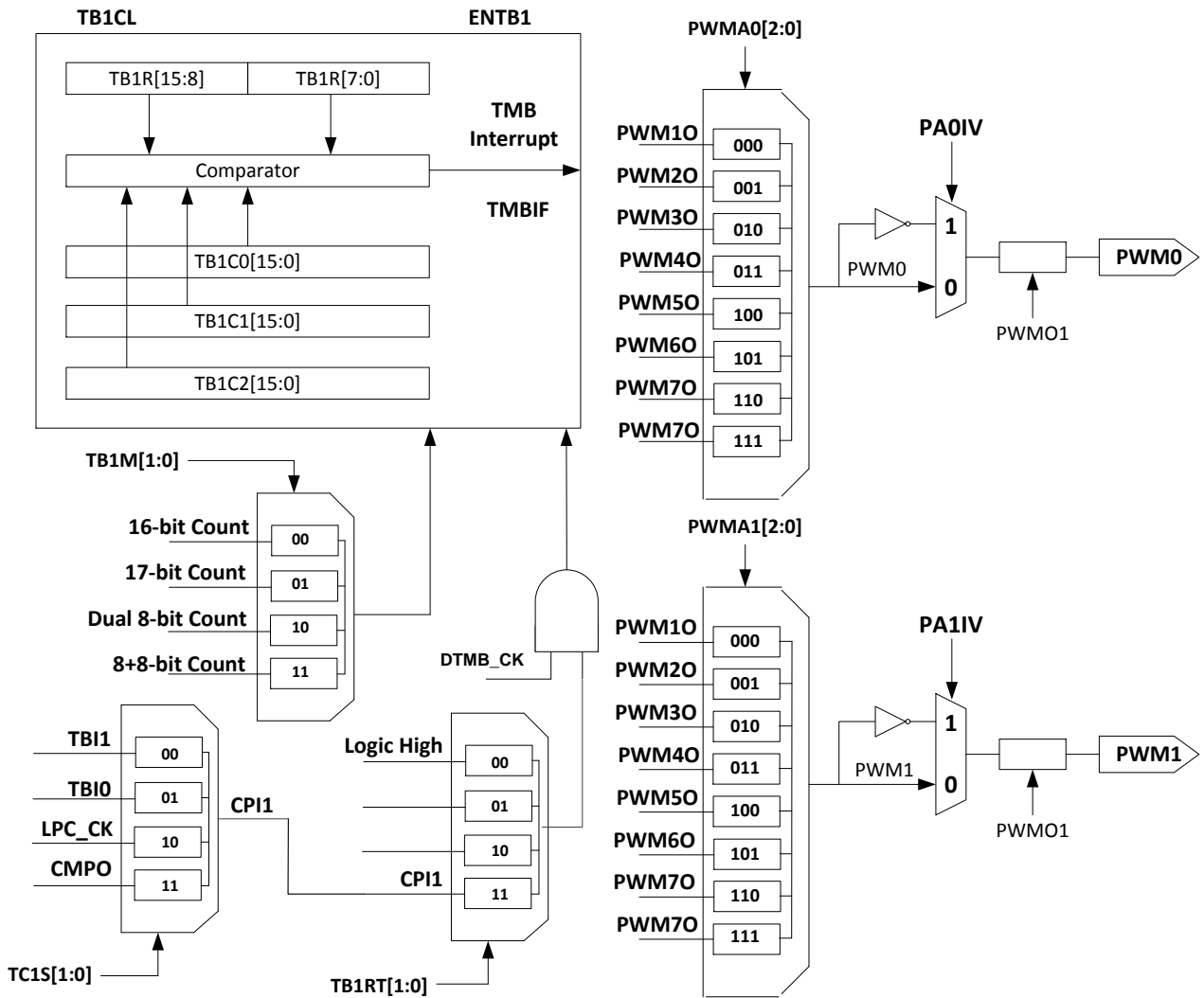

圖 4-20 LCD 方塊圖

**4.18. EUART**

**EUART TRANSMIT BLOCK DIAGRAM**

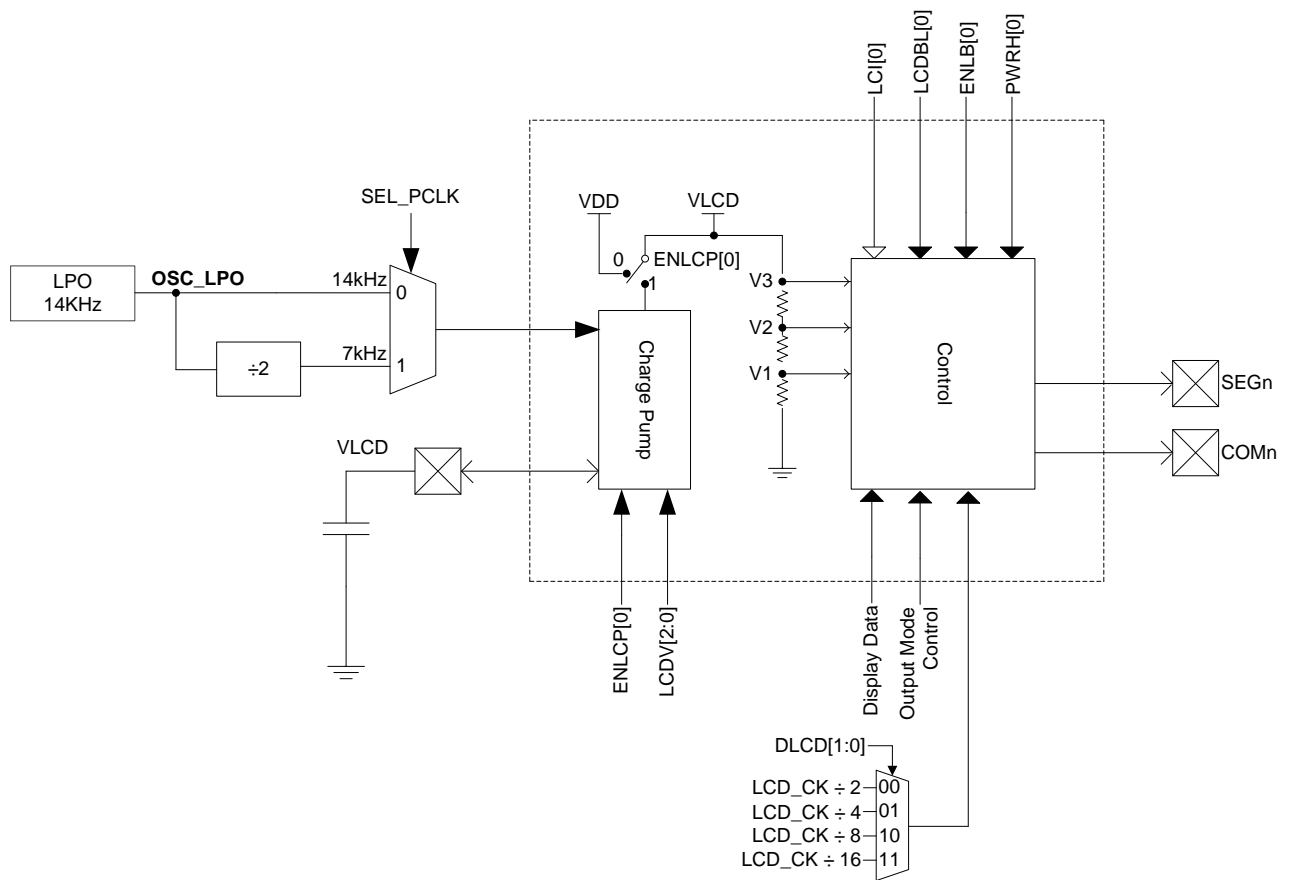

圖 4-21 EUART 傳送方塊圖

**EUART 8-BITS RECEIVE BLOCK DIAGRAM**

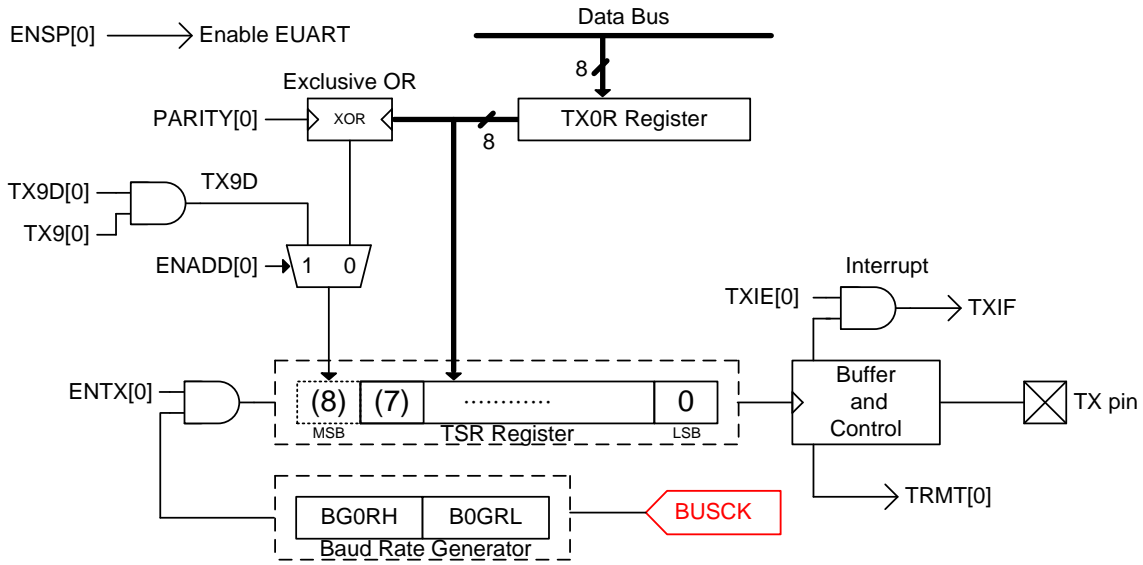
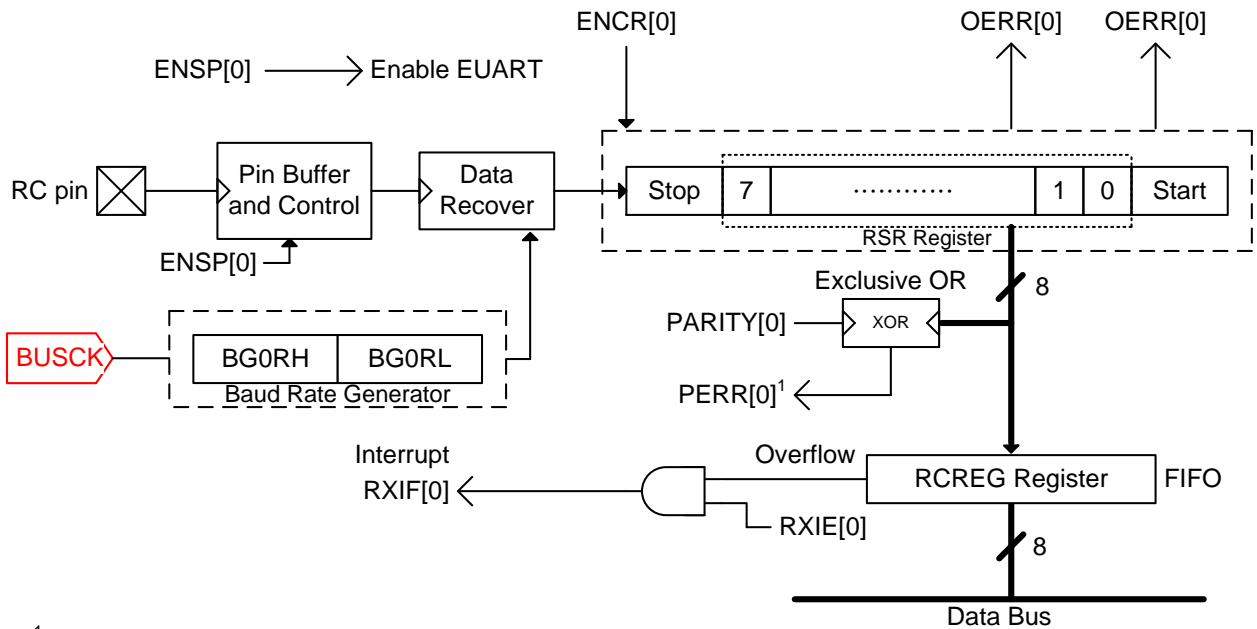

<sup>1</sup>Don't care PERR[0] state of 8-bits receive mode

圖 4-22 EUART 8-bits 接收方塊圖



4.19. I2C



圖 4-23 I<sup>2</sup>C 方塊圖

4.20. SPI

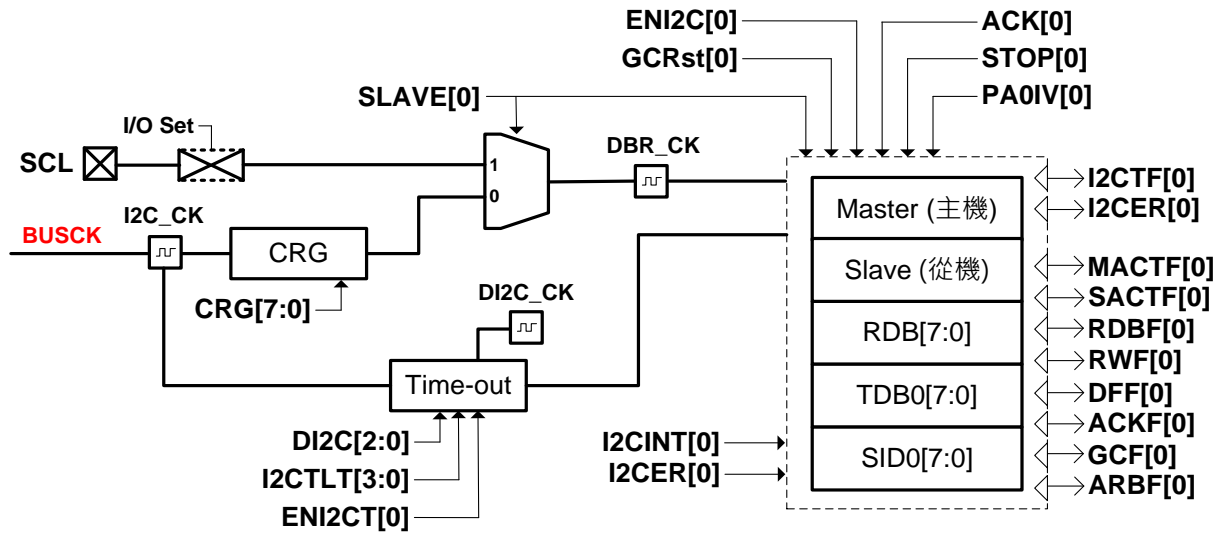

圖 4-24 SPI 方塊圖

## 5. 暫存器列表

“-”no use,“\*”read/write,“w”write,“r”read,“r0”only read 0,“r1”only read 1,“w0”only write 0,“w1”only write 1

“\$”for event status,“.”unimplemented bit,“x”unknown,“u”unchanged,“d”depends on condition

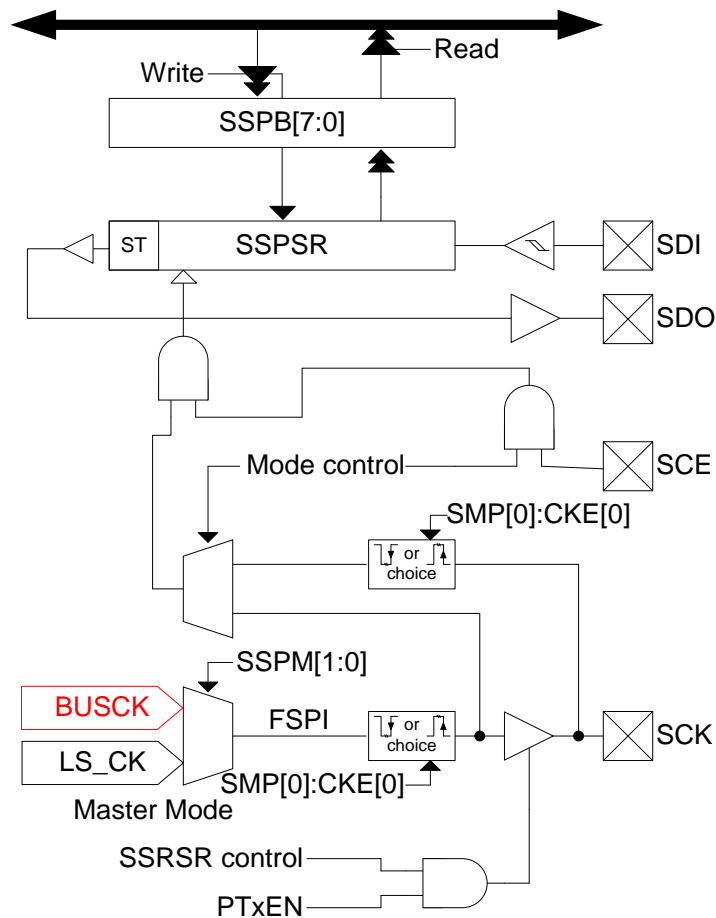
Address	Name	Bit 7	Bit 6	Bit 5	Bit 4	Bit 3	Bit 2	Bit 1	Bit 0	ARST	IRST	R/W
000H	INDF0	Contents of FSR0 to address data memoryvalue of FSR0 not changed								xxxx xxxx	uuuu uuuu	*r,r,w,w
001H	POINC0	Contents of FSR0 to address data memoryvalue of FSR0 post-incremented								xxxx xxxx	uuuu uuuu	*r,r,w,w
002H	PODEC0	Contents of FSR0 to address data memoryvalue of FSR0 post-decremented								xxxx xxxx	uuuu uuuu	*r,r,w,w
003H	PRINC0	Contents of FSR0 to address data memoryvalue of FSR0 pre-incremented								xxxx xxxx	uuuu uuuu	*r,r,w,w
004H	PLUSW0	Contents of FSR0 to address data memoryvalue of FSR0 offset by W								xxxx xxxx	uuuu uuuu	*r,r,w,w
005H	INDF1	Contents of FSR1 to address data memoryvalue of FSR1 not changed								xxxx xxxx	uuuu uuuu	*r,r,w,w
006H	POINC1	Contents of FSR1 to address data memoryvalue of FSR1 post-incremented								xxxx xxxx	uuuu uuuu	*r,r,w,w
007H	PODEC1	Contents of FSR1 to address data memoryvalue of FSR1 post-decremented								xxxx xxxx	uuuu uuuu	*r,r,w,w
008H	PRINC1	Contents of FSR1 to address data memoryvalue of FSR1 pre-incremented								xxxx xxxx	uuuu uuuu	*r,r,w,w
009H	PLUSW1	Contents of FSR1 to address data memoryvalue of FSR1 offset by W								xxxx xxxx	uuuu uuuu	*r,r,w,w
00AH	INDF2	Contents of FSR2 to address data memoryvalue of FSR2 not changed								xxxx xxxx	uuuu uuuu	*r,r,w,w
00BH	POINC2	Contents of FSR2 to address data memoryvalue of FSR2 post-incremented								xxxx xxxx	uuuu uuuu	*r,r,w,w
00CH	PODEC2	Contents of FSR2 to address data memoryvalue of FSR2 post-decremented								xxxx xxxx	uuuu uuuu	*r,r,w,w
00DH	PRINC2	Contents of FSR2 to address data memoryvalue of FSR2 pre-incremented								xxxx xxxx	uuuu uuuu	*r,r,w,w
00EH	PLUSW2	Contents of FSR2 to address data memoryvalue of FSR2 offset by W								xxxx xxxx	uuuu uuuu	*r,r,w,w
00FH	FSR0H	-	-	-	-	-	-	-	FSR0[10:8]	.... xxxx	.... .uuu	*r,r,w,w
010H	FSR0L	Indirect Data Memory Address Pointer 0 Low Byte,FSR0[7:0]								xxxx xxxx	uuuu uuuu	*r,r,w,w
011H	FSR1H	-	-	-	-	-	-	-	FSR1[10:8]	.... .xxx	.... .uuu	*r,r,w,w
012H	FSR1L	Indirect Data Memory Address Pointer 0 Low Byte,FSR1[7:0]								xxxx xxxx	uuuu uuuu	*r,r,w,w
013H	FSR2H	-	-	-	-	-	-	-	FSR2[10:8]	.... .xxx	.... .uuu	*r,r,w,w
014H	FSR2L	Indirect Data Memory Address Pointer 0 Low Byte,FSR2[7:0]								xxxx xxxx	uuuu uuuu	*r,r,w,w
015H	TOSU	-	-	-	-	-	-	-	-	xxxx xxxx	uuuu uuuu	*r,r,w,w
016H	TOSH	Top-of-Stack High Byte (TOS[13:8])								.xxx xxxx	.uu uuuu	*r,r,w,w
017H	TOSL	Top-of-Stack Low Byte (TOS[7:0])								xxxx xxxx	uuuu uuuu	*r,r,w,w
018H	SKCN	SKFL	SKUN	SKOV	SKPRT[4:0]					0000 0000	u\$\$\$ \$\$\$	rw0,rw0,rw0,*r,r,w,w
019H	PCLATU	-	-	-	-	-	-	-	-	xxxx xxxx	uuuu uuuu	*r,r,w,w
01AH	PCLATH	PC High Byte for PC[13:8]								.00 0000	.00 0000	*r,r,w,w
01BH	PCLATL	PC Low Byte for PC[7:0]								0000 0000	0000 0000	*r,r,w,w
01CH	TBLPTRU	-	-	-	-	-	-	-	-	xxxx xxxx	uuuu uuuu	*r,r,w,w
01DH	TBLPTRH	-	-	Program Memory Table Pointer High Byte (TBLPTR[13:8])						.xx xxxx	.uu uuuu	*r,r,w,w
01EH	TBLPTRL	Program Memory Table Pointer Low Byte (TBLPTR[7:0])								xxxx xxxx	uuuu uuuu	*r,r,w,w
01FH	TBLDH	Program Memory Table Latch High Byte								xxxx xxxx	uuuu uuuu	*r,r,w,w
020H	TBLDL	Program Memory Table Latch Low Byte								xxxx xxxx	uuuu uuuu	*r,r,w,w
021H	PRODH	Product Register of Multiply High Byte								xxxx xxxx	uuuu uuuu	*r,r,w,w
022H	PRODL	Product Register of Multiply Low Byte								xxxx xxxx	uuuu uuuu	*r,r,w,w
023H	INTE0	GIE	TA1CIE	ADIE	WDTIE	TB1IE	CTIE	E1IE	E0IE	0000 0000	0uuu uuuu	*r,r,w,w
024H	INTE1	TA1IE	SPIIE	TXIE	RCIE	I2CERIE	I2CIE	E3IE	E2IE	0000 0000	uuuu uuuu	*r,r,w,w
025H	INTE2	MFCIE	CMPOIE	CMPHOIE	CMPLOIE	CTBOVE	RMSIE	LPFIE	BOR2IE	.000 0000	.uuu uuuu	*r,r,w,w
026H	INTF0	-	TA1CIF	ADIF	WDTIF	TB1IF	CTF	E1IF	E0IF	.000 0000	.uuu uuuu	*r,r,w,w
027H	INTF1	TA1IF	SPIIF	TXIF	RCIF	I2CERIF	I2CIF	E3IF	E2IF	0000 0000	uuuu uuuu	*r,r,w,w
028H	INTF2	MFCIF	CMPIF	CMPHIF	CMPLIF	CTBOV	RMSF	LPFF	BOR2IF	0000 0000	uuuu uuuu	*r,r,w,w
029H	WREG	Working Register								xxxx xxxx	uuuu uuuu	*r,r,w,w
02AH	BSRCN	-	-	-	-	-	BSR[2:0]			.... xxxx	.... uuuu	*r,r,w,w
02BH	MSTAT	-	-	-	C	DC	N	OV	Z	...x xxxx	...u uuuu	*r,r,w,w
02CH	PSTAT	BOR	PD	TO	IDL	RST	SKERR	BOR2LV	GCRstIF	\$000 \$000	uu\$u u\$uu	rw0,rw0,rw0,rw0,rw0,rw0,rw0
02DH	BIECN	1	BLKSEL	-	ENBVD	VPPHV	ENBCP	BIEWR	BIERD	1.00 \$000	1.00 \$uuu	r1,*r,*r,*r,*r
02EH	BIEARH	-	BIE High Byte Address Register as BIEA[13:8]						0.xx xxxx	u.uu uuuu	*r,r,w,w	
02FH	BIEARL	BIE Low Byte Address Register as BIEA[7:0]								xxxx xxxx	uuuu uuuu	*r,r,w,w
030H	BIEDRH	BIE High Byte Data Register								xxxx xxxx	uuuu uuuu	*r,r,w,w
031H	BIEDRL	BIE Low Byte Data Register								xxxx xxxx	uuuu uuuu	*r,r,w,w
032H	PWRCN	ENBGR	LDOC[2:0]			LDM[1:0]		ENLDO	CSFON	1000 0000	1uuu u00u	*r,r,w,w
033H	PWRCN1	ENREFO	ENCMP	ENCNTI	ENCTR	ENVS	SAGND[2:0]			0000 0000	uuuu uuuu	*r,r,w,w
034H	PWRCN2	ENPUMP	VGGS	CHP_CKS[1]	CHP_CKS[0]	ENFIR	LDOPL	ENTPS	-	0000 0000	uuuu uuuu	*r,r,w,w
035H	OSCCN0	OSCS[1:0]			DHS[1:0]	DMS[2:0]		CUPS		0000 0000	uuuu uuuu	*r,r,w,w
036H	OSCCN1	CCOPT	LCPS	DADC[1:0]		DTMB[1:0]		TMBS	LCD5	0000 0000	uuuu uu.	*r,r,w,w
037H	OSCCN2	DLCD[1:0]		ENXT	XTS[1:0]		HAOM[1:0]		ENHAO	0000 0001	uuuu uu1	*r,r,w,w

表 5-1 資料記憶體列表

“-”no use, “\*”read/write, “w”write, “r”read, “r0”only read 0, “r1”only read 1, “w0”only write 0, “w1”only write 1

“\$”for event status, “u”unimplemented bit, “x”unknown, “u”unchanged, “d”depends on condition

Address	Name	Bit 7	Bit 6	Bit 5	Bit 4	Bit 3	Bit 2	Bit 1	Bit 0	ARST	IRST	R/W	
038H	CSFCN0	SKRST	HAOTR[6:0]								.1. ....	.... ....	* * * * *
039H	CSFCN1	BUSCKS	-	-	BOR_TH[2:0]			BORS	ENBOR2	0000 0011	uuuu uuuu	* * * * *	
03AH	WDTCN	ENBZ	BZS	DBZ[1:0]		ENWDT	DWDT[2:0]			0000 0000	uuuu \$000	-,*,*,* rw1,*,*,*	
03BH	AD1CN0	ENAD1	ENCH	ENINXCH	VREGN	OSR[2:0]			CMFR	000. 0000	uuu. uuuu	* * * * *	
03CH	AD1CN1	ENACM	VCMS	VCINS	TPSCH	TPSCP	ADGN[2:0]			xxxx xxxx	uuuu uuuu	* * * * *	
03DH	AD1CN2	FilterN[1:0]		-	DAFM	DCSET[3:0]				xxxx xxxx	uuuu uuuu	* * * * *	
03EH	AD1CN3	SAD1FP[3:0]			-	SAD1FN[2:0]				xxxx xxxx	uuuu uuuu	* * * * *	
03FH	AD1CN4	AD1RHBUF	AD1RLBUF	AD1PBUF	AD1NBUF	INX[1:0]		VRIS	INIS	0000 0000	uuuu uuuu	* * * * *	
040H	AD1CN5	SAD1RH[2:0]			SAD1RL[2:0]			SAD1[1:0]		0000 0000	uuuu uuuu	* * * * *	
041H	RMSCN	ENRMS	ENLPF	ENSQRE	LPFBW[1:0]		ENPKH	RSLPF	RSRMS	0000 0000	uuuu uuuu	* * * * *	
042H	NET0	SDIO	SREFO	SFT1[1:0]			SFUVR[3:0]			0000 0000	uuuu uuuu	* * * * *	
043H	NET1	SMODE[7:4]				SMODE[3:0]				0000 0000	uuuu uuuu	* * * * *	
044H	NET2	SCMPRH[3:0]				SCMPRL[3:0]				0000 0000	uuuu uuuu	* * * * *	
045H	NET3	SCMPI[2:0]			SCMPO	CMPO	CMPHO	CMPLO	CNTI_JF	0000 0000	uuuu uuuu	* * * * *	
046H	PA1110	PS11	DS11	FS11	SS11	PS10	DS10	FS10	SS10	0000 0000	uuuu uuuu	* * * * *	
047H	PA98	PS9	DS9	FS9	SS9	PS8	DS8	FS8	SS8	0000 0000	uuuu uuuu	* * * * *	
048H	PA76	PS7	DS7	FS7	SS7	PS6	DS6	FS6	SS6	0000 0000	uuuu uuuu	* * * * *	
049H	PA54	PS5	DS5	FS5	SS5	PS4	DS4	FS4	SS4	0000 0000	uuuu uuuu	* * * * *	
04AH	PA32	PS3	DS3	FS3	SS3	PS2	DS2	FS2	SS2	0000 0000	uuuu uuuu	* * * * *	
04BH	PA10	PS1	DS1	FS1	SS1	PS0	DS0	FS0	SS0	0000 0000	uuuu uuuu	* * * * *	
04CH	CTAU	CTA[23:16]								xxxx xxxx	uuuu uuuu	r,r,r,r r,r,r,r	
04DH	CTAH	CTA[15:8]								xxxx xxxx	uuuu uuuu	r,r,r,r r,r,r,r	
04EH	CTAL	CTA[7:0]								xxxx xxxx	uuuu uuuu	r,r,r,r r,r,r,r	
04FH	CTBU	CTB[23:16]								xxxx xxxx	uuuu uuuu	r,r,r,r r,r,r,r	
050H	CTBH	CTB[15:8]								xxxx xxxx	uuuu uuuu	r,r,r,r r,r,r,r	
051H	CTBL	CTB[7:0]								xxxx xxxx	uuuu uuuu	r,r,r,r r,r,r,r	
052H	CTCU	CTC[23:16]								xxxx xxxx	uuuu uuuu	r,r,r,r r,r,r,r	
053H	CTCH	CTC[15:8]								xxxx xxxx	uuuu uuuu	r,r,r,r r,r,r,r	
054H	CTCL	CTC[7:0]								xxxx xxxx	uuuu uuuu	r,r,r,r r,r,r,r	
055H	PKHMAXU	PKHMAX[18:11]								xxxx xxxx	uuuu uuuu	r,r,r,r r,r,r,r	
056H	PKHMAXH	PKHMAX[10:3]								xxxx xxxx	uuuu uuuu	r,r,r,r r,r,r,r	
057H	PKHMAXL	PKHMAX[2:0]								xxxx xxxx	uuuu uuuu	r,r,r,r r,r,r,r	
058H	PKHMINU	PKHMIN[18:11]								xxxx xxxx	uuuu uuuu	r,r,r,r r,r,r,r	
059H	PKHMINH	PKHMIN[10:3]								xxxx xxxx	uuuu uuuu	r,r,r,r r,r,r,r	
05AH	PKHMINL	PKHMIN[2:0]								xxxx xxxx	uuuu uuuu	r,r,r,r r,r,r,r	
05BH	RMSDATA4	RMS[37:30]								xxxx xxxx	uuuu uuuu	r,r,r,r r,r,r,r	
05CH	RMSDATA3	RMS[29:22]								xxxx xxxx	uuuu uuuu	r,r,r,r r,r,r,r	
05DH	RMSDATA2	RMS[21:14]								xxxx xxxx	uuuu uuuu	r,r,r,r r,r,r,r	
05EH	RMSDATA1	RMS[13:6]								xxxx xxxx	uuuu uuuu	r,r,r,r r,r,r,r	
05FH	RMSDATA0	RMS[5:0]								xxxx xxxx	uuuu uuuu	r,r,r,r r,r,r,r	
060H	LPFDATAU	LPF[18:11]								xxxx xxxx	uuuu uuuu	r,r,r,r r,r,r,r	
061H	LPFDATAH	LPF[10:3]								xxxx xxxx	uuuu uuuu	r,r,r,r r,r,r,r	
062H	LPFDATAL	LPF[2:0]								xxxx xxxx	uuuu uuuu	r,r,r,r r,r,r,r	
063H	AD1DATAU	AD1[18:11]								xxxx xxxx	uuuu uuuu	r,r,r,r r,r,r,r	
064H	AD1DATAH	AD1[10:3]								xxxx xxxx	uuuu uuuu	r,r,r,r r,r,r,r	
065H	AD1DATAL	AD1[2:0]								xxxx xxxx	uuuu uuuu	r,r,r,r r,r,r,r	
066H	OP1CN0	ENOP1	SOP1P[2:0]			OP1CHOP[1:0]		HS	OPS1	0000 0000	uuuu uuuu	* * * * *	
067H	ACC	Capactor array											
068H	TMA1CN	ENTMA1	TMACL1	TMAS1	DTMA1[2:0]			-	-	0000 00.0	u0uu uu.u	*,rw1,*,*,*,*	
069H	TMA1R	TMA1C counter Register											
06AH	TMA1C	TMA1C counter Register											
06BH	PT1	PT1.7	PT1.6	PT1.5	PT1.4	PT1.3	PT1.2	PT1.1	PT1.0	xxxx xxxx	uuuu uuuu	* * * * *	
06CH	PT1IN	IN1.7	IN1.6	IN1.5	IN1.4	IN1.3	IN1.2	IN1.1	IN1.0	0000 0000	uuuu uuuu	* * * * *	
06DH	TRISC1	TC1.7	TC1.6	TC1.5	TC1.4	TC1.3	TC1.2	TC1.1	TC1.0	0000 0000	uuuu uuuu	* * * * *	
06EH	PT1PU	PU1.7	PU1.6	PU1.5	PU1.4	PU1.3	PU1.2	PU1.1	PU1.0	0000 0000	uuuu uuuu	* * * * *	
06FH	PT1M1					INTEG1[1:0]		INTEG0[1:0]		0000 0000	uuuu uuuu	* * * * *	
070H	PT1INT	INTEG7	INTEG6	INTEG5	INTEG4	INTEG3	INTEG2	-	-	0000 0000	uuuu uuuu	* * * * *	
071H	PT1INTE	INTE1.7	INTE1.6	INTE1.5	INTE1.4	-	-	-	-	0000 0000	uuuu uuuu	* * * * *	
072H	PT1INTF	INTF1.7	INTF1.6	INTF1.5	INTF1.4	-	-	-	-	0000 0000	uuuu uuuu	* * * * *	

表 5-2 資料記憶體列表(續)

“-”no use,“\*”read/write,“w”write,“r”read,“r0”only read 0,“r1”only read 1,“w0”only write 0,“w1”only write 1

“\$”for event status,“.”unimplemented bit,“x”unknown,“u”unchanged,“d”depends on condition

Address	Name	Bit 7	Bit 6	Bit 5	Bit 4	Bit 3	Bit 2	Bit 1	Bit 0	ARST	IRST	R/W	
073H	PT2	PT2.7	PT2.6	PT2.5	PT2.4	PT2.3	PT2.2	PT2.1	PT2.0	xxxx xxxx	uuuu uuuu	***r***	
074H	PT2IN	IN2.7	IN2.6	IN2.5	IN2.4	IN2.3	IN2.2	IN2.1	IN2.0	0000 0000	uuuu uuuu	***r***	
075H	TRISC2	TC2.7	TC2.6	TC2.5	TC2.4	TC2.3	TC2.2	TC2.1	TC2.0	0000 0000	uuuu uuuu	***r***	
076H	PT2PU	PU2.7	PU2.6	PU2.5	PU2.4	PU2.3	PU2.2	PU2.1	PU2.0	0000 0000	uuuu uuuu	***r***	
077H	PT2INT	INTG2.7	INTG2.6	INTG2.5	INTG2.4	INTG2.3	INTG2.2	INTG2.1	INTG2.0	0000 0000	uuuu uuuu	***r***	
078H	PT2INTE	INTE2.7	INTE2.6	INTE2.5	INTE2.4	INTE2.3	INTE2.2	INTE2.1	INTE2.0	0000 0000	uuuu uuuu	***r***	
079H	PT2INTF	INTF2.7	INTF2.6	INTF2.5	INTF2.4	INTF2.3	INTF2.2	INTF2.1	INTF2.0	0000 0000	uuuu uuuu	***r***	
07AH	MFCCN0	CPRH[1:0]		MFCO	CPIS	CPOR	CPDF	CMPHS	ENMFC	0000 0000	uuuu uuuu	***r***	
07BH	MFCCN1	CPRL[2:0]		-	CPPS[1:0]		CPNS[1:0]		-	0000 0000	uuuu uuuu	***r***	
07CH	MFCCN2	-	-	-	CPDA[4:0]				-	-	0000 0000	uuuu uuuu	***r***
07DH	MFCCN3	-	-	-	CPDM[4:0]				-	-	0000 0000	uuuu uuuu	***r***
180H	LDCDN1	ENLCP	LCDV[2:0]			ENLB	SELPCLK	LCDBL	ENLCD	0000 0000	uuuu uuuu	***r***	
181H	LDCDN2	-	-	-	-	-	-	-	-	0000 0000	uuuu uuuu	***r***	
182H	LDCDN3	SCM3[1:0]		SCM2[1:0]		SCM1[1:0]		SCM0[1:0]		0000 0000	uuuu uuuu	***r***	
183H	LDCDN4	SSG21	SSG20	SSG19	SSG18	SSG17	SSG16	SSG15	SSG14	0000 0000	uuuu uuuu	***r***	
184H	LDCDN5	-	-	-	-	SSG37	SSG36	SSG35	SSG34	0000 0000	uuuu uuuu	***r***	
185H	LDCDN6	SSG5[1:0]		SSG4[1:0]		SSG3[1:0]		SSG02[1:0]		0000 0000	uuuu uuuu	***r***	
186H	LDCDN7	SSG9[1:0]		SSG8[1:0]		SSG7[1:0]		SSG6[1:0]		0000 0000	uuuu uuuu	***r***	
187H	LDCDN8	SSG13[1:0]		SSG12[1:0]		SSG11[1:0]		SSG10[1:0]		0000 0000	uuuu uuuu	***r***	
188H	LDCDN9	SSG25[1:0]		SSG24[1:0]		SSG23[1:0]		SSG22[1:0]		0000 0000	uuuu uuuu	***r***	
189H	LDCDN10	SSG29[1:1]		SSG28[1:1]		SSG27[1:1]		SSG26[1:1]		0000 0000	uuuu uuuu	***r***	
18AH	LDCDN11	SSG33[1:1]		SSG32[1:1]		SSG31[1:1]		SSG30[1:1]		0000 0000	uuuu uuuu	***r***	
18BH	LCD0	LCD SEG3[4:7] data				LCD SEG2[3:0] data				xxxx xxxx	uuuu uuuu	***r***	
18CH	LCD1	LCD SEG5[4:7] data				LCD SEG4[3:0] data				xxxx xxxx	uuuu uuuu	***r***	
18DH	LCD2	LCD SEG7[4:7] data				LCD SEG6[3:0] data				xxxx xxxx	uuuu uuuu	***r***	
18EH	LCD3	LCD SEG9[4:7] data				LCD SEG8[3:0] data				xxxx xxxx	uuuu uuuu	***r***	
18FH	LCD4	LCD SEG11[4:7] data				LCD SEG10[3:0] data				xxxx xxxx	uuuu uuuu	***r***	
190H	LCD5	LCD SEG13[4:7] data				LCD SEG12[3:0] data				xxxx xxxx	uuuu uuuu	***r***	
191H	LCD6	LCD SEG15[4:7] data				LCD SEG14[3:0] data				xxxx xxxx	uuuu uuuu	***r***	
192H	LCD7	LCD SEG17[4:7] data				LCD SEG16[3:0] data				xxxx xxxx	uuuu uuuu	***r***	
193H	LCD8	LCD SEG19[4:7] data				LCD SEG18[3:0] data				xxxx xxxx	uuuu uuuu	***r***	
194H	LCD9	LCD SEG21[4:7] data				LCD SEG20[3:0] data				xxxx xxxx	uuuu uuuu	***r***	
195H	LCD10	LCD SEG23[4:7] data				LCD SEG22[3:0] data				xxxx xxxx	uuuu uuuu	***r***	
196H	LCD11	LCD SEG25[4:7] data				LCD SEG24[3:0] data				xxxx xxxx	uuuu uuuu	***r***	
197H	LCD12	LCD SEG27[4:7] data				LCD SEG26[3:0] data				xxxx xxxx	uuuu uuuu	***r***	
198H	LCD13	LCD SEG29[4:7] data				LCD SEG28[3:0] data				xxxx xxxx	uuuu uuuu	***r***	
199H	LCD14	LCD SEG31[4:7] data				LCD SEG30[3:0] data				xxxx xxxx	uuuu uuuu	***r***	
19AH	LCD15	LCD SEG33[4:7] data				LCD SEG32[3:0] data				xxxx xxxx	uuuu uuuu	***r***	
19BH	LCD16	LCD SEG35[4:7] data				LCD SEG34[3:0] data				xxxx xxxx	uuuu uuuu	***r***	
19CH	LCD17	LCD SEG37[4:7] data				LCD SEG36[3:0] data				xxxx xxxx	uuuu uuuu	***r***	
19DH	LCD18	LCD SEG39[4:7] data				LCD SEG38[3:0] data				xxxx xxxx	uuuu uuuu	***r***	
19EH	LCD19	LCD SEG41[4:7] data				LCD SEG40[3:0] data				xxxx xxxx	uuuu uuuu	***r***	
19FH	PT3	PT3.7	PT3.6	PT3.5	PT3.4	PT3.3	PT3.2	PT3.1	PT3.0	xxxx xxxx	uuuu uuuu	***r***	
1A0H	PT3IN	IN3.7	IN3.6	IN3.5	IN3.4	IN3.3	IN3.2	IN3.1	IN3.0	0000 0000	uuuu uuuu	***r***	
1A1H	TRISC3	TC3.7	TC3.6	TC3.5	TC3.4	TC3.3	TC3.2	TC3.1	TC3.0	0000 0000	uuuu uuuu	***r***	
1A2H	PT3PU	PU3.7	PU3.6	PU3.5	PU3.4	PU3.3	PU3.2	PU3.1	PU3.0	0000 0000	uuuu uuuu	***r***	
1A3H	PT3M1	PM3.7	ENPCMP0	-	-	-	-	-	-	0000 0000	uuuu uuuu	***r***	
1A4H	PT4	-	-	-	-	-	PT4.2	PT4.1	PT4.0	xxxx xxxx	uuuu uuuu	***r***	
1A5H	PT4IN	-	-	-	-	-	IN3.2	IN3.1	IN3.0	xxxx 0000	uuuu uuuu	***r***	
1A6H	TRISC4	-	-	-	-	-	TC4.2	TC4.1	TC4.0	xxxx 0000	uuuu uuuu	***r***	
1A7H	PT4PU	-	-	-	-	-	PU4.2	PU4.1	PU4.0	xxxx 0000	uuuu uuuu	***r***	
1A8H	PT6	PT6.7	PT6.6	PT6.5	PT6.4	PT6.3	PT6.2	PT6.1	PT6.0	xxxx xxxx	uuuu uuuu	***r***	
1A9H	PT6IN	IN6.7	IN6.6	IN6.5	IN6.4	IN6.3	IN6.2	IN6.1	IN6.0	0000 xxxx	uuuu uuuu	***r***	
1AAH	TRISC6	TC6.7	TC6.6	TC6.5	TC6.4	TC6.3	TC6.2	TC6.1	TC6.0	0000 xxxx	uuuu uuuu	***r***	
1ABH	PT6PU	PU6.7	PU6.6	PU6.5	PU6.4	PU6.3	PU6.2	PU6.1	PU6.0	0000 xxxx	uuuu uuuu	***r***	
1ACH	PT7	PT7.7	PT7.6	PT7.5	PT7.4	PT7.3	PT7.2	PT7.1	PT7.0	xxxx xxxx	uuuu uuuu	***r***	
1ADH	PT7IN	IN7.7	IN7.6	IN7.5	IN7.4	IN7.3	IN7.2	IN7.1	IN7.0	0000 0000	uuuu uuuu	***r***	
1AEH	TRISC7	TC7.7	TC7.6	TC7.5	TC7.4	TC7.3	TC7.2	TC7.1	TC7.0	0000 0000	uuuu uuuu	***r***	
1AFH	PT7PU	PU7.7	PU7.6	PU7.5	PU7.4	PU7.3	PU7.2	PU7.1	PU7.0	0000 0000	uuuu uuuu	***r***	

表 5-3 資料記憶體列表(續)

“-”no use,“\*”read/write,“w”write,“r”read,“r0”only read 0,“r1”only read 1,“w0”only write 0,“w1”only write 1  
 “\$”for event status,“.”unimplemented bit,“x”unknown,“u”unchanged,“d”depends on condition

Address	Name	Bit 7	Bit 6	Bit 5	Bit 4	Bit 3	Bit 2	Bit 1	Bit 0	ARST	IRST	R/W	
1B0H	PT8	PT8.7	PT8.6	PT8.5	PT8.4	PT8.3	PT8.2	PT8.1	PT8.0	xxxx xxxx	uuuu uuuu	*****	
1B1H	PT8IN	IN8.7	IN8.6	IN8.5	IN8.4	IN8.3	IN8.2	IN8.1	IN8.0	0000 0000	uuuu uuuu	*****	
1B2H	TRISC8	TC8.7	TC8.6	TC8.5	TC8.4	TC8.3	TC8.2	TC8.1	TC8.0	0000 0000	uuuu uuuu	*****	
1B3H	PT8PU	PU8.7	PU8.6	PU8.5	PU8.4	PU8.3	PU8.2	PU8.1	PU8.0	0000 0000	uuuu uuuu	*****	
1B4H	PT9	PT9.7	PT9.6	PT9.5	PT9.4	PT9.3	PT9.2	PT9.1	PT9.0	xxxx xxxx	uuuu uuuu	*****	
1B5H	PT9IN	IN9.7	IN9.6	IN9.5	IN9.4	IN9.3	IN9.2	IN9.1	IN9.0	0000 0000	uuuu uuuu	*****	
1B6H	TRISC9	TC9.7	TC9.6	TC9.5	TC9.4	TC9.3	TC9.2	TC9.1	TC9.0	0000 0000	uuuu uuuu	*****	
1B7H	PT9PU	PU9.7	PU9.6	PU9.5	PU9.4	PU9.3	PU9.2	PU9.1	PU9.0	0000 0000	uuuu uuuu	*****	
1B8H	PT10	PT10.7	PT10.6	PT10.5	PT10.4	PT10.3	PT10.2	PT10.1	PT10.0	xxxx xxxx	uuuu uuuu	*****	
1B9H	PT10IN	IN10.7	IN10.6	IN10.5	IN10.4	IN10.3	IN10.2	IN10.1	IN10.0	0000 0000	uuuu uuuu	*****	
1BAH	TRISC10	TC10.7	TC10.6	TC10.5	TC10.4	TC10.3	TC10.2	TC10.1	TC10.0	0000 0000	uuuu uuuu	*****	
1BBH	PT10PU	PU10.7	PU10.6	PU10.5	PU10.4	PU10.3	PU10.2	PU10.1	PU10.0	0000 0000	uuuu uuuu	*****	
1C0H	SSPCN0	ENSSP	CKP	CKE	SMP	-	-	SSPM[1:0]		0000 ..00	uuuu ..uu	***-***	
1C1H	SSPSTA0	SSPBY	SSPOV	-	-	-	-	-	BF	00.. ...0	uu.. ....u	**--***	
1C2H	SSPBUF0	SSP Receive/Transmit Buffer Register								xxxx xxxx	uuuu uuuu	*****	
1C3H	CFG0	-	-	-	-	-	GCRst	ENI2CT	ENI2C	0000 0000	.... uuuu	---***	
1C4H	ACT0	SLAVE	-	-	I2CER	START	STOP	I2CINT	ACK	0000 0000	uuuu uuuu	*****	
1C5H	STA0	MACTF	SACTF	RDBF	RWF	DFF	ACKF	GCF	ARBF	0001 0000	uuuu uuuu	*****	
1C6H	CRG0	CRG[7:0]								0000 0000	uuuu uuuu	*****	
1C7H	TOC0	I2CTF	DI2C[2:0]			I2CTLT[3:0]				0000 0000	uuuu uuuu	*****	
1C8H	RDB0	RDB[7:1]						RDB[0]		xxxx xxxx	uuuu uuuu	*****	
1C9H	TDB0	TDB0[7:1]						TDB0[0]		xxxx xxxx	uuuu uuuu	*****	
1CAH	SID0	SID0[7:1].The corresponding address of the 7-bit mode							SID0V[0]		0000 0000	uuuu uuuu	*****
1CBH	UR0CN	ENSP	ENTX	TX9	TX9D	PARITY	-	-	WUE	0000 0..0	uuuu u..u	***-***	
1CCH	UR0STA	-	RC9D	PERR	FERR	OERR	RCIDL	TRMT	ABDOVF	.000 0010	.uuu uuuu	-,r,r,r,r,r,r,w0	
1CDH	BA0CN	-	-	-	-	ENCR	RC9	ENADD	ENABD	.... 0000	.... uuuu	---***	
1CEH	BG0RH	-	-	-	Baud Rate Generator Register High Byte					...x xxxx	...u uuuu	---***	
1CFH	BG0RL	Baud Rate Generator Register Low Byte								xxxx xxxx	uuuu uuuu	*****	
1D0H	TX0R	UART Transmit Register											
1D1H	RC0REG	UART Receive Register											
1D2H	TB1Flag		PWM7A	PWM6A	PWM5A	PWM4A	PWM3A	PWM2A	PWM1A	.000 0000	.uuu uuuu	-,r,r,r,r,r,r	
1D3H	TB1CN0	ENTB1	TB1M[1:0]		TB1RT[1:0]		TB1CL	PWMO1	PWMO0	0000 0000	uuuu u0uu	***-*,rw1,*	
1D4H	TB1CN1	PA1IV	PWMA1[2:0]			PA0IV	PWMA0[2:0]			0000 0000	uuuu uuuu	*****	
1D5H	TB1RH	TimerB1 counter Register [15:8]											
1D6H	TB1RL	TimerB1 counter Register [7:0]											
1D7H	TB1C0H	TimerB1 counter Condition Register [15:8]											
1D8H	TB1C0L	TimerB1 counter Condition Register [7:0]											
1D9H	TB1C1H	TimerB1 counter Condition Register [15:8]											
1DAH	TB1C1L	TimerB1 counter Condition Register [7:0]											
1DBH	TB1C2H	TimerB1 counter Condition Register [15:8]											
1DCH	TB1C2L	TimerB1 counter Condition Register [7:0]											
1DDH	TB1CN2	-	TC1S[1:0]		-	-	-	-	-	0000 0000	uuuu uuuu	uuuu uuuu	
1DEH	DGCON1	-	-	-	DGRST	DGDiv[2:0]			DGEN	0000 0000	uuuu uuuu	*****	
1DFH	DGCON2	-	-	DGRP[5:0]						0000 0000	uuuu uuuu	*****	
1E0H	DACCN0	DANS[1:0]		DAPS[1:0]		-	-	DALH	ENDA	0000 0000	uuuu uuuu	*****	
1E1H	DACCN1	DABIT[7:0]											
1E2H	FILTER	FreSpect		Frebit	ENSpect	-	-	-	-	0000 0000	uuuu uuuu	*****	
080h ~ 0FFh	SRAM as 128Byte										uuuu uuuu	uuuu uuuu	*****
100h ~ 17Fh	SRAM as 128Byte										uuuu uuuu	uuuu uuuu	*****
200h ~ 2FFh	SRAM as 256Byte										uuuu uuuu	uuuu uuuu	*****
300h ~ 3FFh	SRAM as 256Byte, 300h~33Fh set for hardware sinewave first.										uuuu uuuu	uuuu uuuu	*****
400h ~ 4FFh	SRAM as 256Byte										uuuu uuuu	uuuu uuuu	*****

表 5-4 資料記憶體列表(續)

## 6. 電氣特性

### Absolute Maximum Ratings:

Absolute maximum ratings over operating free-air temperature (unless otherwise noted)

Voltage applied at V <sub>DD</sub> to V <sub>SS</sub> .....	-0.2 V to 6.0 V
Voltage applied to any pin .....	-0.2 V to V <sub>DD</sub> + 0.3 V
Voltage applied to RST/VPP pin .....	-0.2 V to 8.75 V
Diode current at any device terminal .....	±2 mA
Storage temperature, Tstg: (unprogrammed device) .....	-55°C to 125°C
(programmed device) .....	-40°C to 85°C
Total power dissipation .....	0.5W
Maximum output current sink by any I/O pin .....	.20mA

### 6.1. Recommended operating conditions

T<sub>A</sub> = -40°C ~ 85°C, unless otherwise noted

Sym.	Parameter		Test Conditions	Min.	Typ.	Max.	unit
V <sub>DD</sub>	Supply Voltage		All digital peripherals and CPU V <sub>DD</sub> = 2.2V~5.5V, Frequency<=9.6MHz, V <sub>DD</sub> = 3.6V~5.5V, Frequency<=16MHz,	2.2		5.5	V
V <sub>DDA</sub>	Supply Voltage		Analog peripherals	2.4		4.5	
V <sub>SS</sub>	Supply Voltage			0		0	
XT	External Oscillator Frequency	Watch crystal	V <sub>DD</sub> = 2.2V~5.5V, ENXT[0]=1	XTS[1:0]=0x	32768		Hz
		Ceramic resonator, Crystal		XTS[1:0]=10	450K	4M	
				XTS[1:0]=11	1M	8M	
		Ceramic resonator, Crystal	V <sub>DD</sub> = 3.6V~5.5V, ENXT[0]=1	XTS[1:0]=11	450K	16M	

### 6.2. Internal RC Oscillator

T<sub>A</sub> = 25°C, V<sub>DD</sub> = 3.0V, unless otherwise noted

Sym.	Parameter	Test Conditions	Min.	Typ.	Max.	unit
HAO	High Speed Oscillator frequency	ENHAO[0]=1, HAOM[1:0]=01	-20%	4.9152	+20%	MHz
		ENHAO[0]=1, HAOM[1:0]=11	-20%	9.8304	+20%	
LPO	Low Power Oscillator frequency	V <sub>DD</sub> supply voltage be enable LPO	-20%	14.5	+20%	kHz

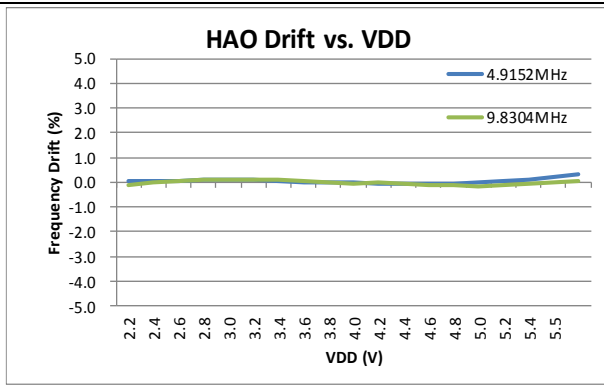

Figure 6.2-1 HAO vs. VDD

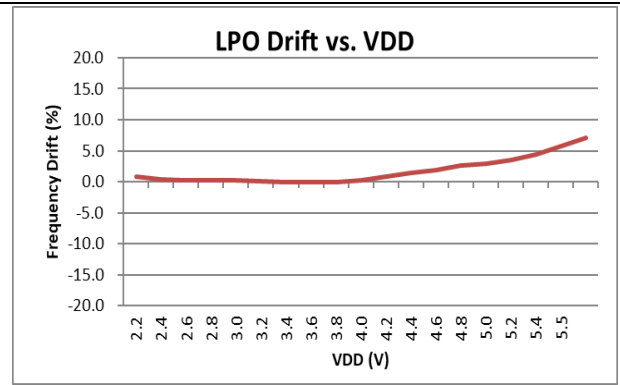

Figure 6.2-2 LPO vs. VDD

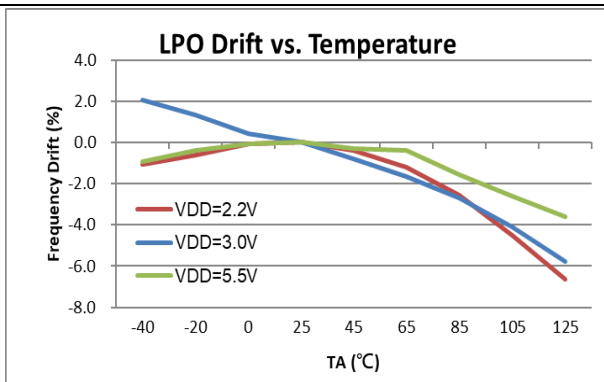

Figure 6.2-3 LPO vs. Temperature

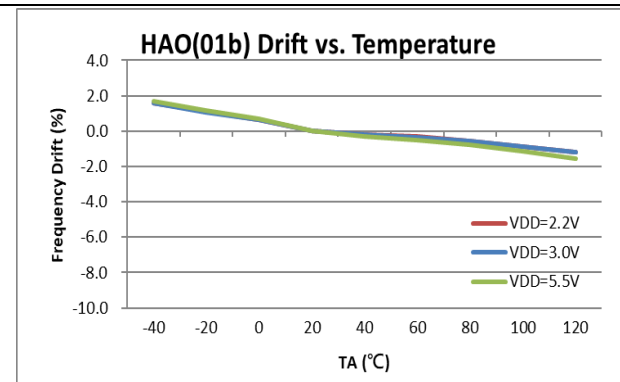

Figure 6.2-4 HAO(4.9152MHz) vs. Temperature

### 6.3. Supply current into VDD excluding peripherals current

$T_A = 25^\circ\text{C}, V_{DD} = 3.0\text{V}, \text{OSC\_LPO} = 14.5\text{KHz}$ , unless otherwise noted

Sym.	Parameter	Test Conditions	Min.	Typ.	Max.	unit
I <sub>AM1</sub>	Active mode 1	OSC_CY = off, OSC_HAO = 4.9152MHz, CPU_CK = 4.9152MHz		550	800	uA
I <sub>AM2</sub>	Active mode 2	OSC_CY = off, OSC_HAO = 4.9152MHz, CPU_CK = 4.9152MHz/2		500	700	uA
I <sub>LP1</sub>	Low Power 1	OSC_CY = off, OSC_HAO = off, CPU_CK = LPO,		2	5	uA
I <sub>LP2</sub>	Low Power 2	OSC_CY = off, OSC_HAO = off, CPU_CK = LPO, Idle state		1.0	2.5	uA
I <sub>LP3</sub>	Low Power 3	OSC_CY = off, OSC_HAO = off, CPU_CK = off, Sleep state		0.25	1.0	uA

OSC\_CY : External Oscillator frequency.

OSC\_HAO : Internal High Accuracy Oscillator frequency.

CPU\_CK : CPU core work frequency.

$T_A = 25^\circ\text{C}, V_{DD} = 5.5\text{V}, \text{OSC\_LPO} = 14.5\text{KHz}$ , unless otherwise noted

Sym.	Parameter	Test Conditions	Min.	Typ.	Max.	unit
I <sub>AM1</sub>	Active mode 1	OSC_CY = off, OSC_HAO = 4.9152MHz, CPU_CK = 4.9152MHz		1000	1500	uA
I <sub>AM2</sub>	Active mode 2	OSC_CY = off, OSC_HAO = 4.9152MHz, CPU_CK = 4.9152MHz/2		900	1300	uA
I <sub>LP1</sub>	Low Power 1	OSC_CY = off, OSC_HAO = off, CPU_CK = LPO,		4	10	uA
I <sub>LP2</sub>	Low Power 2	OSC_CY = off, OSC_HAO = off, CPU_CK = LPO, Idle state		2.5	5	uA
I <sub>LP3</sub>	Low Power 3	OSC_CY = off, OSC_HAO = off, CPU_CK = off, Sleep state		0.4	2	uA

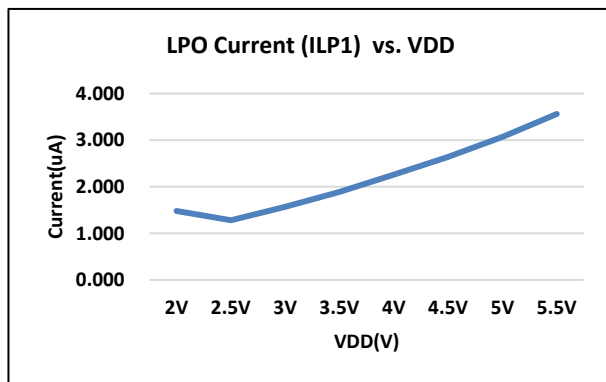

Figure 6.3-1 I<sub>AM1</sub> vs. VDD

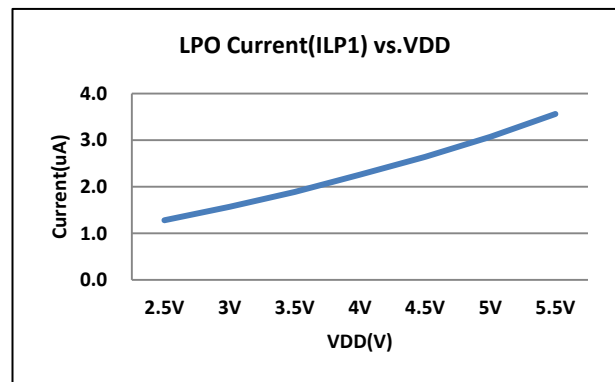

Figure 6.3-2 I<sub>LP1</sub> vs. VDD

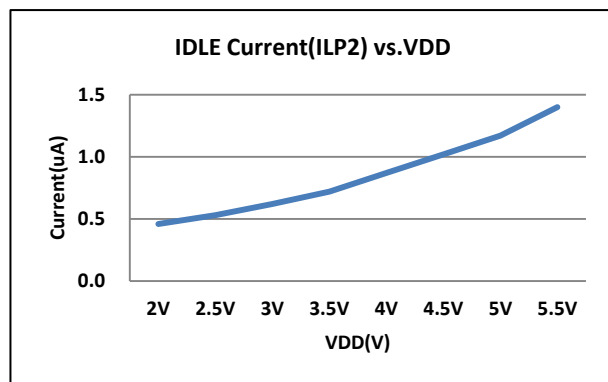

Figure 6.3-3 I<sub>LP2</sub> vs. VDD

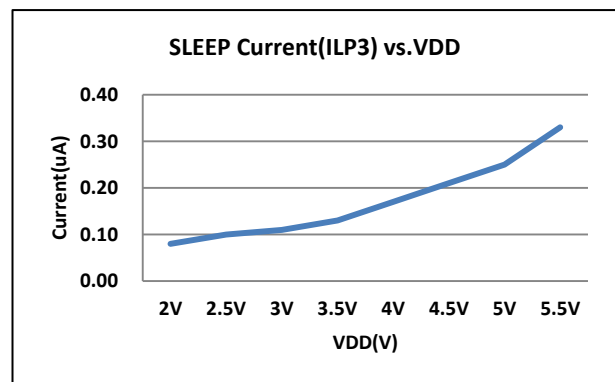

Figure 6.3-4 I<sub>LP3</sub> vs. VDD



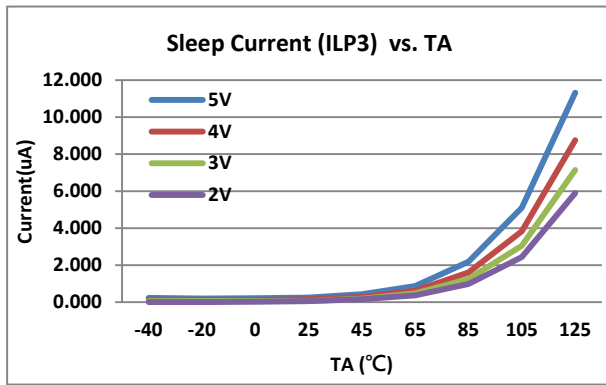

Figure 6.3-2 I<sub>LP3</sub> vs. Temperature

**6.4. Port 1~4,6~10**

T<sub>A</sub> = 25°C, VDD = 3.0V, unless otherwise noted

Sym.	Parameter	Test Conditions	Min.	Typ.	Max.	unit
<b>Input voltage and Schmitt trigger and leakage current and timing</b>						
V <sub>IH</sub>	High-Level input voltage				0.7*VDD	V
V <sub>IL</sub>	Low-Level input voltage		0.3*VDD			
V <sub>hys</sub>	Input Voltage hysteresis(V <sub>IH</sub> - V <sub>IL</sub> )			0.3*VDD		V
I <sub>LKG</sub>	Leakage Current				0.1	uA
R <sub>PU</sub>	Port pull high resistance			60		kΩ
<b>Output voltage and current and frequency</b>						
V <sub>OH</sub>	High-level output voltage	VDD<4V, I <sub>OH</sub> =10mA,	VDD -0.4			V
		VDD>=4V, I <sub>OH</sub> =15mA,	VDD -0.4			
V <sub>OL</sub>	Low-level output voltage	VDD<4V, I <sub>OL</sub> =-10mA	VSS +0.4			V
		VDD>=4V, I <sub>OL</sub> =-15mA	VSS +0.4			

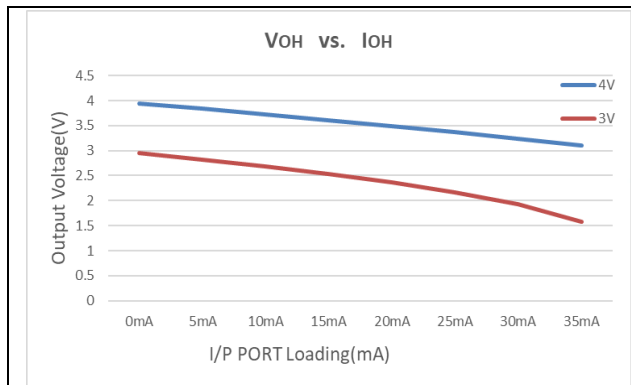

Figure 6.4-1 V<sub>OH</sub> vs. I<sub>OH</sub>

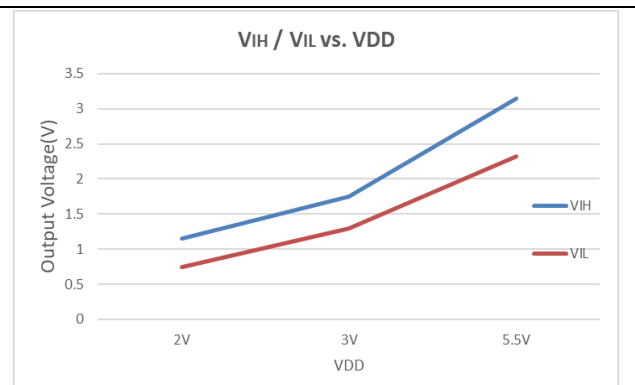

Figure 6.4-2 V<sub>IH</sub>/V<sub>IL</sub> vs. VDD

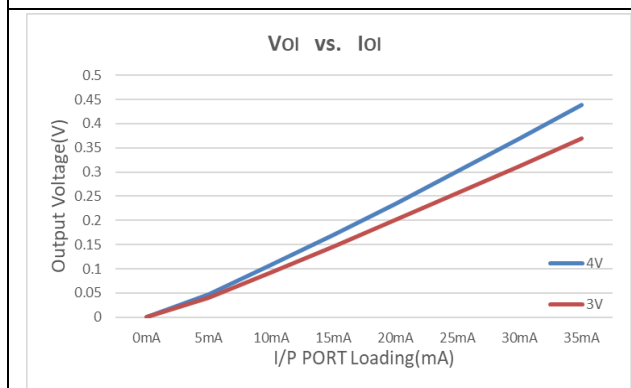

Figure 6.4-3 V<sub>OL</sub> vs. I<sub>OL</sub>

### 6.5. Reset(Brownout)

$T_A = 25^\circ\text{C}, V_{DD} = 3.0\text{V}$ , unless otherwise noted

Sym.	Parameter	Test Conditions	Min.	Typ.	Max.	unit	
BOR1	Pulse length needed to accepted reset internally, $t_{d-LVR1}$		2			us	
	$V_{DD}$ Start Voltage to accepted reset internally (L→H), $V_{HYS1}$		1.0	1.35	1.65	V	
	BOR1 current, $I_{BOR1}$		0.2			0.5	uA
	Temperature Drift		5			%	
BOR2	Pulse length needed to accepted reset internally, $t_{d-LVR2}$		2			us	
	$V_{DD}$ Start Voltage to accepted reset internally (L→H), $V_{HYS2}$ , and BOR_TH[2:0]:	000b	-8%	1.73	+8%	V	
		001b	-8%	2.0	+8%		
		010b	-8%	2.22	+8%		
		011b	-8%	2.5	+8%		
		100b	-8%	2.72	+8%		
		101b	-8%	3.0	+8%		
		110b	-10%	3.63	+10%		
		111b	-10%	4.0	+10%		
	$V_{DD}$ Start Voltage to accepted reset internally (H→L), $V_{LVR2}$ , and BOR_TH[2:0]:	000b	-8%	1.67	+8%	V	
		001b	-8%	1.96	+8%		
		010b	-8%	2.17	+8%		
		011b	-8%	2.44	+8%		
		100b	-8%	2.69	+8%		
		101b	-8%	2.96	+8%		
		110b	-10%	3.58	+10%		
		111b	-10%	3.94	+10%		
	Hysteresis, $V_{HYS2-LVR2}$		25	60	90	mV	
	BOR2 current, $I_{BOR2}$		25			35	uA
	Temperature Drift		3			5	%
RST	Pulse length needed as RST/VPP pin to accepted reset internally, $t_{d-RST}$		2			us	
	Input Voltage to accepted reset voltage		1.1			V	
	Reset release voltage		2			V	
BOR1/BOR2 : Brownout Reset 1/2 LVR : Low Voltage Reset of BOR RST : External Reset pin							

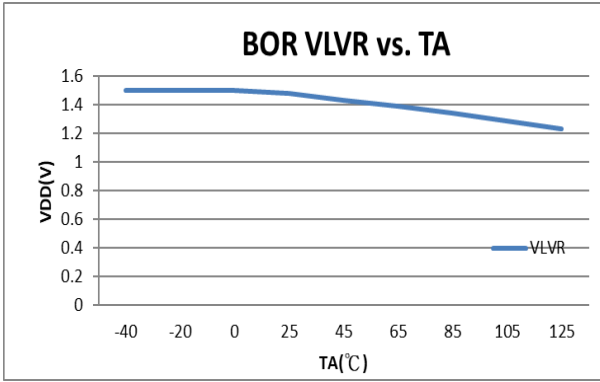

Figure 6.5-1 BOR vs. Temperature

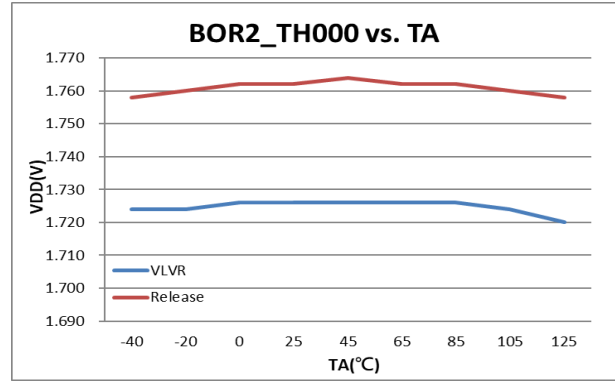

Figure 6.5-2 BOR2 vs. Temperature

**6.6. Multi-function Comparator**

T<sub>A</sub> = 25°C, V<sub>DD</sub> = 3.0V, unless otherwise noted.

Sym.	Parameter	Test Conditions	Min.	Typ.	Max.	Unit
I <sub>MC</sub>	Operation supply current	ENCMP[0]=1, CMPHS[0]=1b		5		uA
	Low Power Mode	ENCMP[0]=1, CMPHS [0]=0b		1		
V <sub>IC</sub>	Common-mode input voltage		0		V <sub>DD</sub> -1	V
V <sub>OS</sub>	Offset voltage		-5		5	mV
V <sub>hys</sub>	Input hysteresis		0	0.7	1.5	mV
V <sub>accy</sub>	Reference Voltage	ENLDO[0]=1b, CPPS[1:0]=11b,	1.15	1.2	1.25	V
	Temperature Drift	VRSEL[0]=1b		50		ppm/°C
	VDD Voltage drift			±0.2		%/V
I <sub>R</sub>	Multi-node resistor current	CPRL[0]=0b		10		uA
		CPRL[0]=1b		30		
	ENLDO[0]=1b, CPPS[1:0]=11b, CPRH [1:0]=01b, CPRL[0]=0b.	CPDA[4:0]=00011b	-5%	5%	3.89	V
		CPDA[4:0]=00100b			3.73	
		CPDA[4:0]=00101b			3.58	
		CPDA[4:0]=00110b			3.44	
		CPDA[4:0]=00111b			3.31	
		CPDA[4:0]=01000b			3.19	
		CPDA[4:0]=01001b			3.08	
		CPDA[4:0]=01010b			2.98	
		CPDA[4:0]=01011b			2.88	
		CPDA[4:0]=01100b			2.79	
		CPDA[4:0]=01101b			2.71	
		CPDA[4:0]=01110b			2.63	
		CPDA[4:0]=01111b			2.55	
		CPDA[4:0]=10000b			2.48	
		CPDA[4:0]=10001b			2.42	
		CPDA[4:0]=10010b			2.35	
		CPDA[4:0]=10011b			2.29	
		CPDA[4:0]=10100b			2.24	
CPDA[4:0]=00011b~10100b						

**6.7. Power System**

T<sub>A</sub> = 25°C, VDD = 3.0V, unless otherwise noted

Sym.	Parameter	Test Conditions		Min.	Typ.	Max.	unit
VDDA	VDDA operation current, I <sub>VDDA</sub>	I <sub>L</sub> = 0mA	LDOC[2:0]=000b	30			uA
	Select VDDA output voltage	I <sub>L</sub> = 0.1mA, VDD ≥ VDDA+0.25V ENPUMP=1b	LDOC [2:0]=000b	-5%	2.4	+5%	V
			LDOC [2:0]=001b		2.6		V
			LDOC [2:0]=010b		2.9		V
			LDOC [2:0]=011b		3.3		V
			LDOC [2:0]=100b		3.6		V
			LDOC [2:0]=101b		4.0		V
			LDOC [2:0]=110b		4.5		V
	Dropout voltage	VDD=2.9V I <sub>L</sub> = 10mA	LDOC [2:0]=010b	200			mV
Temperature drift	LDOC [2:0]=000b I <sub>L</sub> = 0.1mA	T <sub>A</sub> =-40°C~85°C	50			PPM/°C	
V <sub>DD</sub> Voltage drift	LDOC [2:0]=000b	V <sub>DD</sub> =2.2V~5.5V	±0.2			%/V	
AGND	AGND operation current, I <sub>Agnd</sub>	SAGND ≠ 000b ENPUMP=1b VGGS=1b	I <sub>L</sub> = 0mA	450			uA
	Output voltage, V <sub>Agnd</sub>	SAGND=001b	I <sub>L</sub> = 10uA	-5%	VDDA*0.3	-5%	
		SAGND=010b	I <sub>L</sub> = 10uA	-5%	VDDA*0.1	-5%	
		SAGND=011b	I <sub>L</sub> = 10uA	-5%	VDDA*0.5	-5%	
		SAGND=100b	I <sub>L</sub> = 10uA	-5%	VDDA*0.4	-5%	
REFO	V(REFO,VSS)		I <sub>L</sub> = 10uA	-3%	1,2	-3%	V
	Temperature drift		T <sub>A</sub> =-40°C~85°C	100			PPM/°C
	RMS Noise			60			uVrms

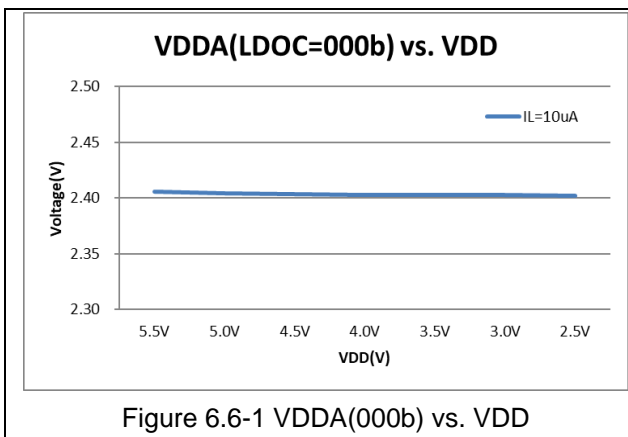

Figure 6.6-1 VDDA(000b) vs. VDD

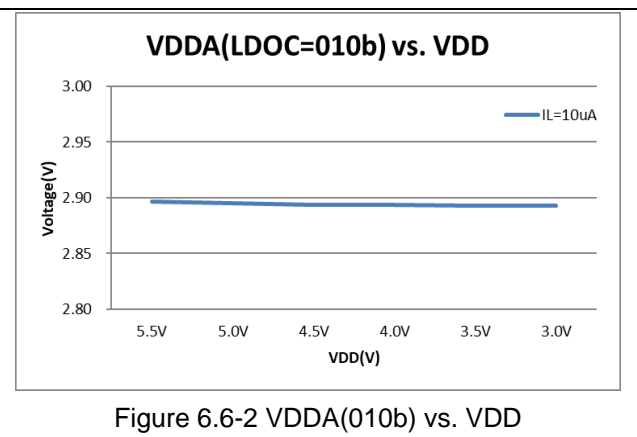

Figure 6.6-2 VDDA(010b) vs. VDD

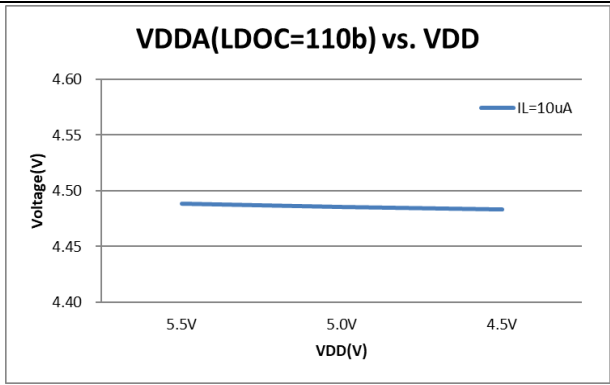

Figure 6.6-3 VDDA(110b) vs. VDD

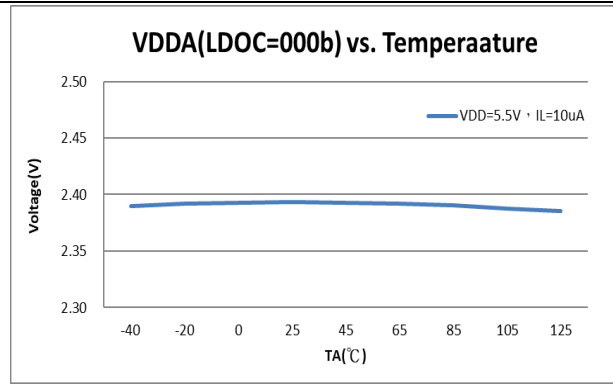

Figure 6.6-4 VDDA(000b) vs. Temperature

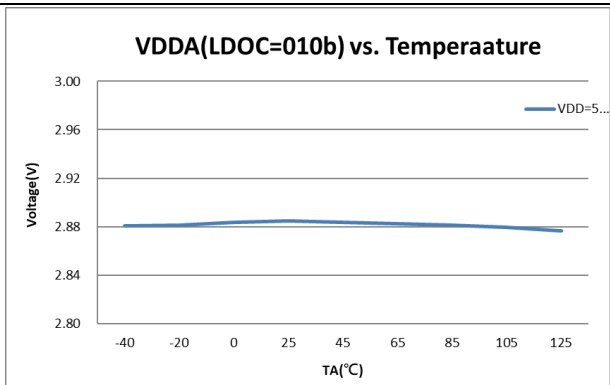

Figure 6.6-5 VDDA(010b) vs. Temperature

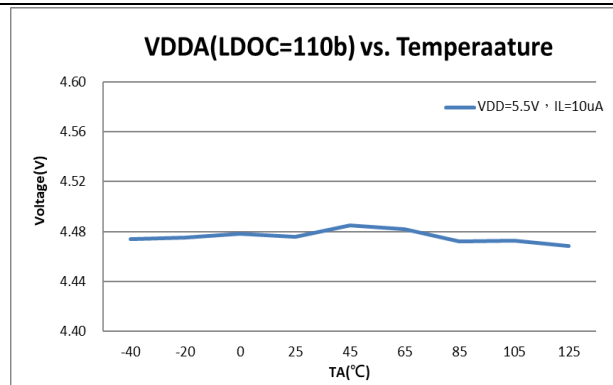

Figure 6.6-6 VDDA(110b) vs. Temperature

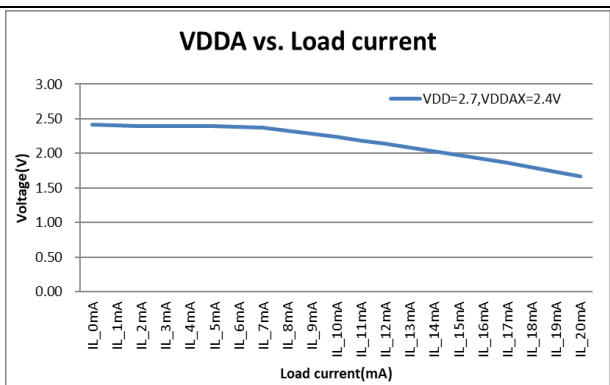

Figure 6.6-7 VDDA vs. Load current

**6.8. LCD**

T<sub>A</sub> = 25°C, V<sub>DD</sub> = 3.3V, C<sub>VLCD</sub> = 4.7uF, unless otherwise noted.

Sym.	Parameter	Test Conditions	Min.	Typ.	Max.	unit	
I <sub>LCD</sub>	Operation supply current with output buffer.(all segment turn on, No load)	ENLCP[0]=1 V <sub>DD</sub> = 3.0V		8		uA	
V <sub>LCD</sub>	Supply Voltage at VLCD pin	ENLCP [0]=0	2.4		5	V	
	Embedded Charge Pump output voltage at VLCD pin	V <sub>DD</sub> = 3.3V, ENLCP [0]=1, C <sub>VLCD</sub> =4.7uF	LCDV[2:0]=111b	-10%	2.45	+10%	V
			LCDV[2:0]=110b	-10%	2.70	+10%	
			LCDV[2:0]=101b	-10%	2.85	+10%	
			LCDV[2:0]=100b	-10%	3.10	+10%	
			LCDV[2:0]=011b	-10%	3.30	+10%	
			LCDV[2:0]=010b	-10%	4.10	+10%	
			LCDV[2:0]=001b (VDD>2.4V mode)	-10%	4.55	+10%	
LCDV[2:0]=000b (VDD>2.75V)	-10%	5.1	+10%				
VDD Voltage drift	ENLCP [0]=1, C <sub>VLCD</sub> =4.7uF, LCDV[2:0]>010b,VDD=2.2V~ 5.5V; LCDV[2:0]=001b,VDD>2.4V; LCDV[2:0]=000b,VDD>2.75V;			4		%/V	
Z <sub>LCD</sub>	Output impedance with LCD buffer	f <sub>LCD</sub> =128Hz,VLCD=3.05V		10		kΩ	

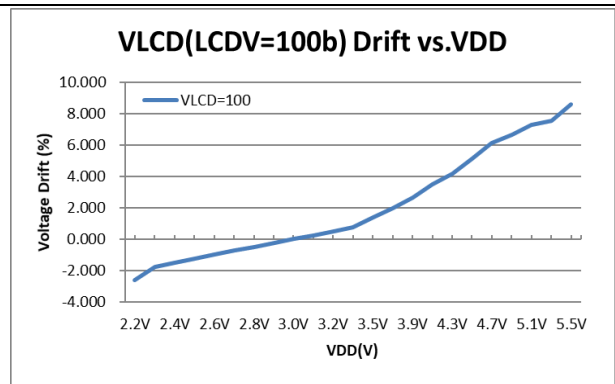

Figure 6.7-1 VLCD(LCDV=100b) vs. VDD

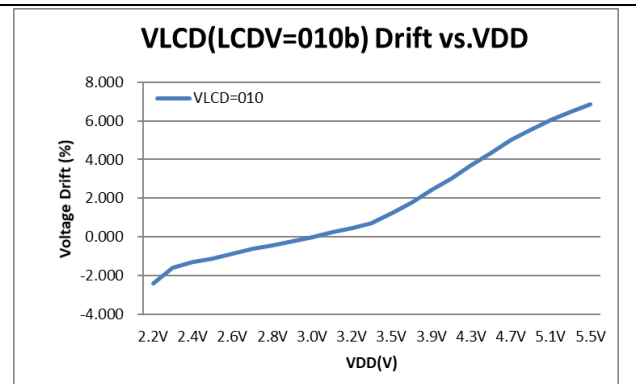

Figure 6.7-2 VLCD(LCDV=010b) vs. VDD

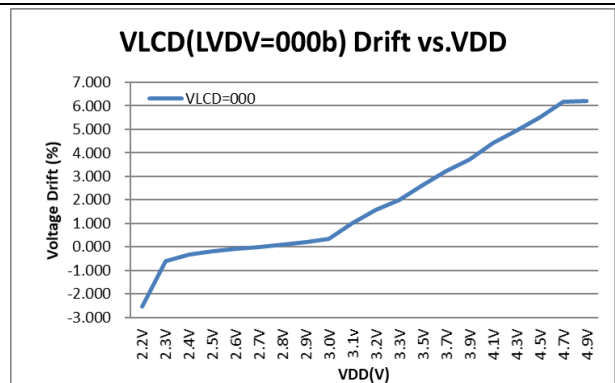

Figure 6.7-3 VLCD(LCDV=000b) vs. VDD



### 6.9. OPAMP

TA = 25°C, VDD = 3.3V, VDDA=2.4V, AGND=0.3VDDA, Input buffer on unless otherwise noted

Sym.	Parameter	Test Conditions	Min.	Typ.	Max.	Unit
<b>V<sub>os-op</sub></b>	Input offset voltage	Pre-Filter=10K(Inside) / 27nF(Outside) OP Unity Gain, HS=1b,OP1CHOP=00b			800	uV
<b>V<sub>os-td</sub></b>	OP Input offset temperature drift	TA=-40°C ~ 85°C		0.5		uV/°C
<b>CMVR</b>	Common-mode voltage input range		VSS+0.1		VDDA - 1.1	V

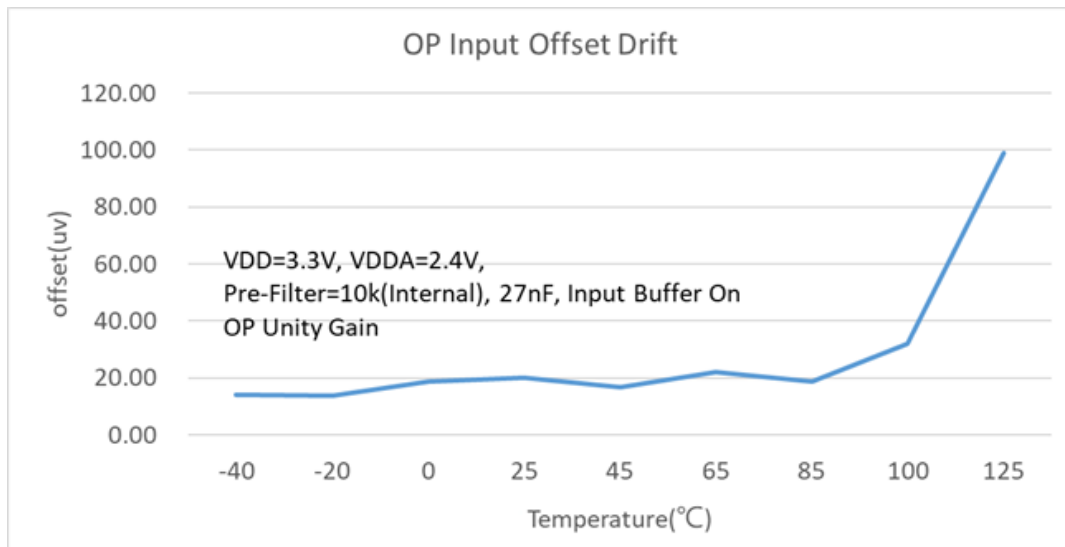

**6.10. ΣADC, Power Supply and recommended operating conditions**

T<sub>A</sub> = 25°C, VDD = 3.0V, VDDA=2.4V, unless otherwise noted

Sym.	Parameter	Test Conditions		Min.	Typ.	Max.	unit
V <sub>SD18</sub>	Supply Voltage at VDDA	ENLDO[0]=0		2.4		5.5	V
f <sub>SD18</sub>	Modulator sample frequency, ADC_CK				0.5		MHz
	Over Sample Ratio, OSR			32		61440	
Eos	Input offset voltage	Chopper on OSR=61440 Input Buffer On Pre-Filter:10k, 27nF	Input gain=1, reference gain=1		-3		uV
			Input gain=8, reference gain=1		-3		
Rev	Roll-over error voltage	Chopper on OSR=61440	Input gain=1, reference gain=1				uV
			Input gain=8, reference gain=1				
Vrms	Input RMS Noise	Chopper on, OSR=61440, input gain=1.0 reference gain=1	Chopper on, OSR=61440, input gain=8.0 reference gain=1		.35		uV
			Chopper off, OSR=32, input gain=1.0 reference gain=1, ADC_CK=1MHz		750		
			Chopper off, OSR=32, input gain=8.0 reference gain=1, ADC_CK=1MHz		330		
NM	Normal Rejection ratio	Chopper On OSR=61440 ADCLK=1	Input gain=1.0, reference gain=1. Vin=200mVrms 50/60Hz		60		dB
AC <sub>bw</sub>	AC Measurement Bandwidth	OSR=32, LPFBW=2048 Without Voltage Dividers	0.5% error	20		4k	Hz
			3dB				
			Square wave, 0.5% error			0.3k	
			Triangle wave, 0.5% error				

# HY17P68

## 6000 Counts Digital RMS DMM

		<i>ENOB(RMS) with OSR/GAIN at A/D Clock=0.5MHz, VDD=3.3V, VDDA=2.4V, AGND=0.3VDDA, VREF=1.2, Vin=Ext.Short, Chopper Off;</i>						
A/D Clock=1M Hz	OSR	64	128	256	7680	15360	30720	61140
Output rate(Hz)	31250	7813	3906	1953	65	33	16	8
Gain								
0.5	11.97	13.74	14.8	15.43	17.87	18.29	18.67	18.89
1	11.66	13.56	14.76	15.65	17.77	18.24	18.49	18.73
2	11.23	12.43	14.85	15.18	17.56	17.88	18.21	18.32
4	10.61	12.67	14.52	15.03	17.14	17.5	17.47	17.68
8	9.82	11.92	14.1	14.57	16.42	16.66	16.88	16.67
		<i>RMS Noise(uV) with OSR/GAIN at A/D Clock=0.5MHz, VDD=3.3V, VDDA=2.4V, AGND=0.3VDDA, VREF=1.2, Vin=Ext.Short, Chopper Off;</i>						
A/D Clock=1M Hz	OSR	64	128	256	7680	15360	30720	61140
Output rate(Hz)	31250	7813	3906	1953	65	33	16	8
Gain								
0.5	1197.70	349.75	168.30	108.85	20.02	14.99	11.49	9.87
1	744.08	198.44	86.65	46.74	10.77	7.75	6.53	5.52
2	499.79	217.13	40.69	32.42	6.19	4.96	3.95	3.67
4	383.17	92.21	25.53	17.98	4.15	3.25	3.29	2.85
8	331.64	77.68	17.12	12.37	3.43	2.89	2.48	2.88

<i>ENOB(RMS) with OSR/GAIN at A/D Clock=0.5MHz, VDD=3.3V, VDDA=2.4V, AGND=0.3VDDA, VREF=1.2, Vin=Ext.Short, Chopper On;</i>							
OSR	64	128	256	7680	15360	30720	61140
Output rate(Hz)	3906	1953	977	33	16	8	4
Gain							
0.5	14.75	15.36	15.9	18.27	18.65	19.06	19.43
1	14.69	15.32	15.91	18.24	18.65	19.06	19.41
2	14.62	15.31	15.84	18.27	18.55	18.9	19.16
4	14.51	15.11	15.66	17.91	18.23	18.52	18.73
8	14.19	14.77	15.18	17.29	17.61	17.84	17.9
<i>RMS Noise(uV) with OSR/GAIN at A/D Clock=0.5MHz, VDD=3.3V, VDDA=2.4V, AGND=0.3VDDA, VREF=1.2, Vin=Ext.Short, Chopper On;</i>							
OSR	64	128	256	7680	15360	30720	61140
Output rate(Hz)	3906	1953	977	33	16	8	4
Gain							
0.5	174.57	114.32	78.73	15.16	11.70	8.77	6.79
1	90.77	58.72	39.09	7.75	5.85	4.39	3.45
2	47.53	29.46	20.47	3.79	3.13	2.45	2.05
4	25.75	16.97	11.57	2.43	1.95	1.60	1.38
8	16.08	10.75	8.07	1.88	1.50	1.28	1.23

### 6.10.1. $\Sigma$ ADC ,Temperature Sensor

$T_A = 25^\circ\text{C}, V_{DD} = 3.0\text{V}, V_{DDA}=2.4\text{V}$ , unless otherwise noted

Sym.	Parameter	Test Conditions	Min.	Typ.	Max.	unit
$TC_S$	Sensor temperature drift			173		$\mu\text{V}/^\circ\text{C}$
KT	Absolute Temperature Scale $0^\circ\text{K}$			-263		$^\circ\text{C}$
$TC_{ERR}$	One point calibrate error temperature	Calibration at $25^\circ\text{C}$ of $-40^\circ\text{C}\sim 85^\circ\text{C}$		$\pm 2$		$^\circ\text{C}$

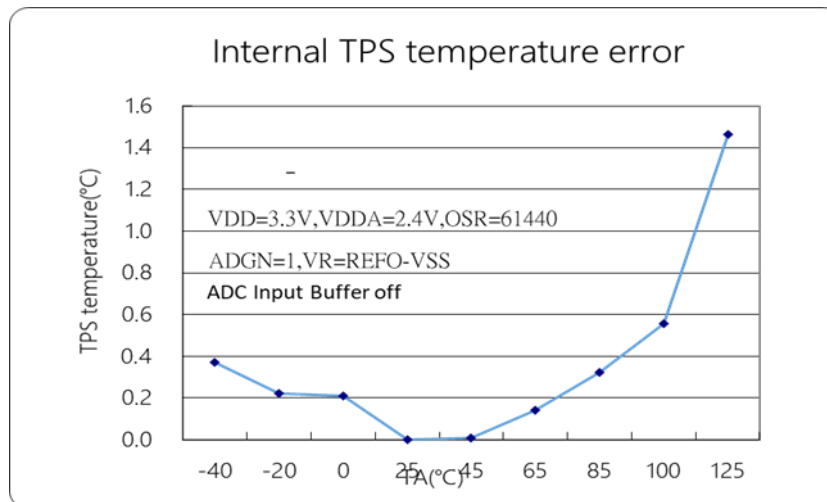

Figure 6.8-4 ADC Temperature Error

### 6.11. Analog input and switch performance

$T_A = 25^\circ\text{C}, V_{DD} = 3.0\text{V}, V_{DDA}=2.4\text{V}$  AGND=0.5 x VDDA, unless otherwise noted

Sym.	Parameter	Test Conditions	Min.	Typ.	Max.	unit
$I_{AL}$	Analog Input Leakage Current	AGND=0.5 x VDDA		10	100	pA
		AGND=0.4 x VDDA		10	100	
		AGND=0.3 x VDDA		10	100	
		AGND=0.1 x VDDA		100	500	
Rsw	Switch Turn On Resistance	PS0,PS1		20		Ohm
		DS0,DS1		40		
		DS2~DS8, PS2~PS8		80		
		SS0~SS8,FS0~FS8		400		

### 6.12. Windows Comparator

$T_A = 25^\circ\text{C}, V_{DD} = 3.0\text{V}, V_{DDA}=2.4\text{V}$  AGND=0.5 x VDDA ,unless otherwise noted

Sym.	Parameter	Test Conditions	Min.	Typ.	Max.	unit
$I_{CMP}$	Comparator Supply Current					$\mu\text{A}$
$V_I$	Comparator Input Range	CMPL	0		$V_{DDA}-0.7$	V
		CMPH	0.4		VDDA	

# HY17P68

## 6000 Counts Digital RMS DMM

Vos	Comparator Input Offset	CMPL , VRLCMP=AGND	5	mV
	Voltage	CMPH VRHCMP=AGND	5	
Vn	Comparator Input peak to peak noise	CMPL	5	mV
		CMPH	5	
		CMPH&CMPL	10	
CMP <sub>BW</sub>	Comparator Bandwidth	VRHCMP=AGNDP<2>, VRLCMP=AGNDN<2> VIN=100mVrms	1	MHz

**6.13. Build-In EPROM(BIE)**

$T_A = 25^{\circ}\text{C}, V_{DD} = 3.0\text{V}$ , unless otherwise noted

Sym.	Parameter	Test Conditions	Min.	Typ.	Max.	unit
$V_{BIE}$	Supply Voltage at VPP PIN			8.5	8.75	V
$I_{BIE}$	Operation supply current			3		mA
$V_{SS}$	Supply Voltage			0		V

When connecting to the external  $V_{BIE}$  power source to program the BIE block, users can use the instruction to program the words one by one into the BIE block.

**6.14. Build-In EPROM(BIE) Low voltage control circuit**

$T_A = 25^{\circ}\text{C}, V_{DD} = 3.05\text{V}$ , unless otherwise noted

Sym.	Parameter	Test Conditions	Min.	Typ.	Max.	unit
$T_O$	Operation temperature range		0	25	40	$^{\circ}\text{C}$
$V_{DD}$	Operation supply Voltage		2.75		5.5	V
$V_{SS}$	Supply Voltage			0		V

When the 2.75V low voltage programming control circuit is activated, users can program the BIE block without connecting to the external  $V_{BIE}$  power source.



圖 6.14-1 BIE typical application 方塊圖



圖 6.14-2 BIE typical application use low voltage control circuit 方塊圖

## 7. 修訂貨資訊

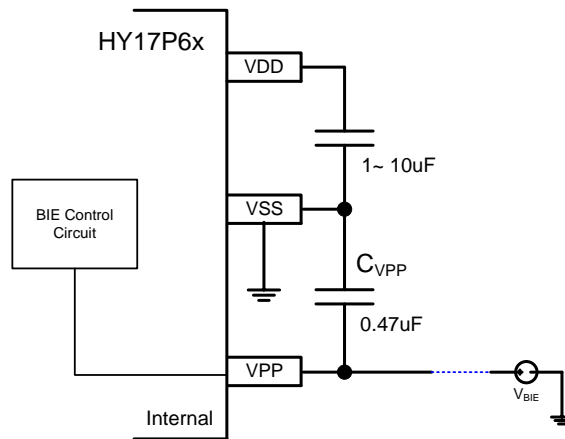
下單品名 1	封裝型式	引腳數	封裝型式		程式碼	出貨包裝 形式	個裝 數量	材料 組成	MSL3
			描述方式		編號 2				
HY17P68-D000	Die	-	D	000	000	Tray	200	Green <sup>4</sup>	-
HY17P68-L064	LQFP	64	L	064	000	Tray	250	Green <sup>4</sup>	MSL-3
HY17P68-L100	LQFP	100	L	100	000	Tray	90	Green <sup>4</sup>	MSL-3

<sup>1</sup> 產品名稱 品名封裝型式描述方式 裝型程式碼編號 (空白片 / 標準品 / 代客燒錄碼)

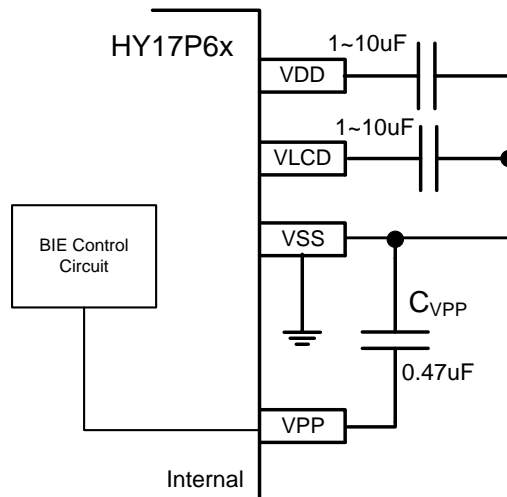
例如：您的 HY17P68 代客燒錄服務申請的程式碼編號為 001，且需要的產品是裸片出貨。則下單品名為 HY17P68-D000-001。

例如：您的需求是 HY17P68 不帶程式碼的空白片且需要的產品是裸片出貨。則下單品名為 HY17P68-D000。

例如：您的需求是 HY17P68 不帶程式碼的空白片且需要的產品是封裝片 LQFP64 出貨，則下單品名為 HY17P68-L064，且需以 Tray 出貨，則除下單品名外，請特別註明出貨包裝形式為 Tray。

例如：您的 HY17P68 代客燒錄服務申請的程式碼編號為 001，而需求的產品是封裝片 LQFP64 出貨，則下單品名為 HY17P68-L064-001，且需以 Tray 出貨，則除下單品名外，請特別註明出貨包裝形式為 Tray。

<sup>2</sup> 程式碼編號

“式碼編號式為品名外，請為標準品或代客燒錄申請的程式碼編號，而空白晶片不帶此碼。

<sup>3</sup> MSL:

濕度敏感性等級係依據 IPC/JEDEC J-STD-020 的規範加以試驗分級，並參考 IPC/JEDEC J-STD-033 的標準處理、包裝、運輸與使用。

<sup>4</sup> Green (RoHS & no Cl/Br):

HYCON 產品皆為 Green Product，符合 RoHS 指令，REACH 高關注物質(SVHC)以及無鹵素規定 (Br<900ppm or Cl<900ppm or (Br+Cl)<1500ppm)。

## 8. 封裝型式資訊

### 8.1. LQFP64(L064)

#### 8.1.1. Package Dimensions LQFP64(7x7)

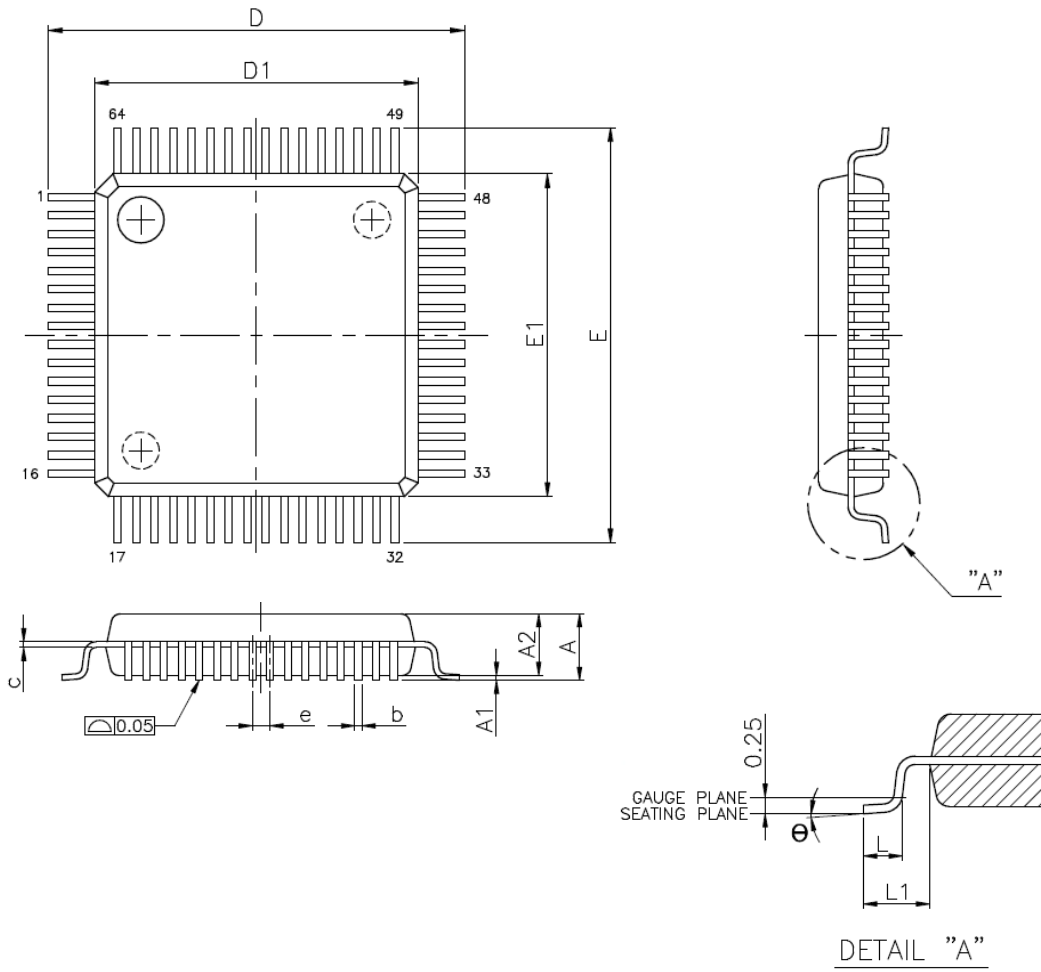

SYMBOLS	MIN.	NOM.	MAX.
A	—	—	1.60
A1	0.05	—	0.15
A2	1.35	1.40	1.45
b	0.13	0.18	0.23
c	0.09	—	0.20
D	9.00 BSC		
D1	7.00 BSC		
e	0.40 BSC		
E	9.00 BSC		
E1	7.00 BSC		
L	0.45	0.60	0.75
L1	1.00 REF		
$\theta$	0°	3.5°	7°

Note:

1. All dimensions refer to JEDEC OUTLINE MS-026.
2. Do not include Mold Flash or Protrusions.
3. Unit: mm.



**8.2. LQFP100(L100)**

**8.2.1. Package Dimensions LQFP100(14x14)**

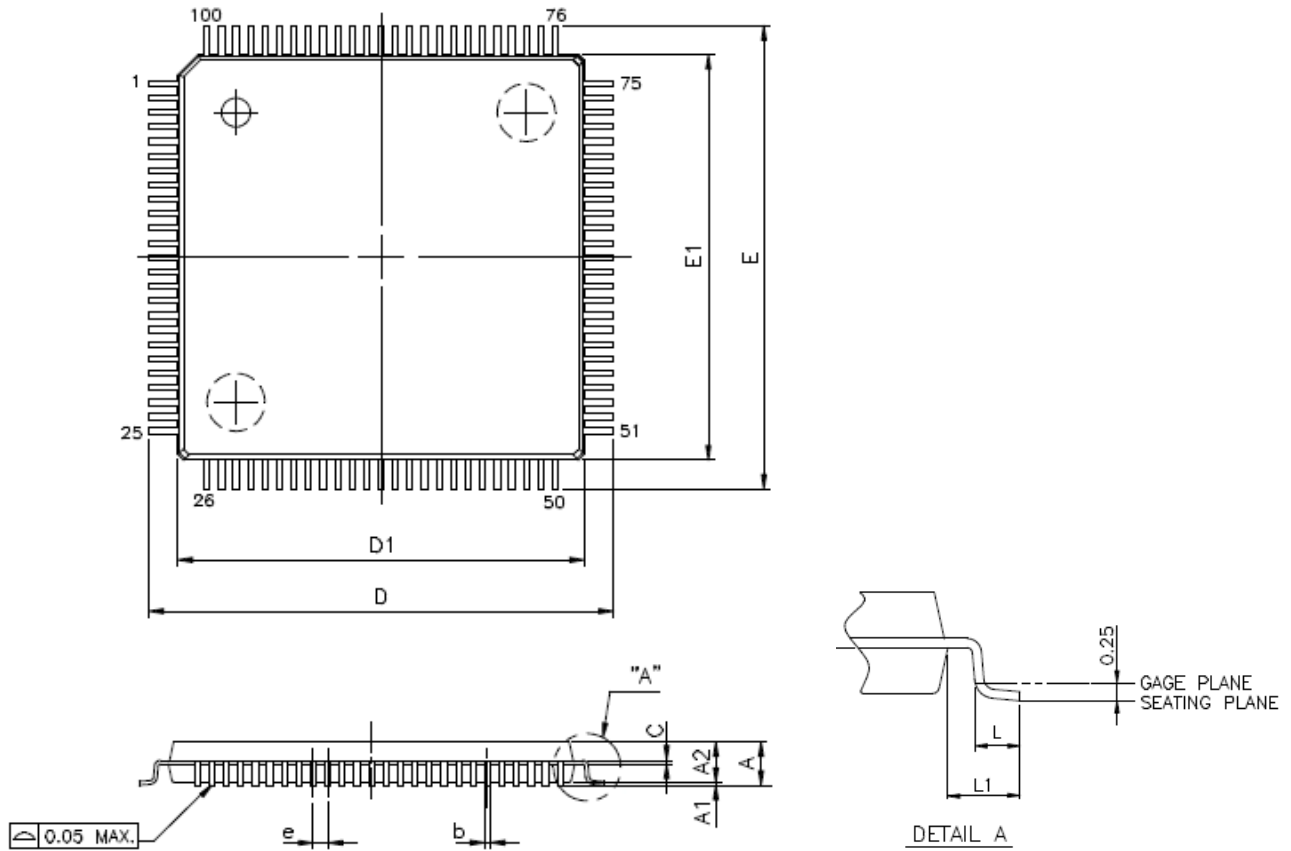

SYMBOLS	MIN.	NOM.	MAX.
A	--	--	1.60
A1	0.05	--	0.15
A2	1.35	1.40	1.45
b	0.17	0.20	0.27
c	0.09	0.127	0.20
D	16.00 BSC		
D1	14.00 BSC		
E	16.00 BSC		
E1	14.00 BSC		
e	0.50 BSC		
L	0.45	0.60	0.75
L1	1.00 REF		

Note:

1. All dimensions refer to JEDEC OUTLINE MS-026.
2. Do not include Mold Flash or Protrusions.
3. Unit: mm.

## 9. 修訂記錄

以下描述本檔差異較大的地方，而標點符號與字形的改變不在此描述範圍。

文件版次	頁次	日期	摘要
V01	All	2021/10/21	初版發行
V02	All	2022/12/16	修改 4.11 OPAMP 方塊圖